

EMICON

INNOVATION AS ENERGY



AN ENEX TECHNOLOGIES COMPANY

GROUND SOURCE WATER TO WATER HEAT PUMPS

WZA

SERIES



R410A

TECHNICAL MANUAL

Incorporated in this document are the following:

- Declaration of conformity
- Technical manual

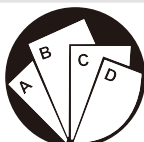

Multiple instructions:
Consult the specific part



Read and understand
the instructions before
undertaking any work on
the unit

RETAIN FOR FUTURE REFERENCE

Reproduction, data storage and transmission, even partial, of this publication, in any form, without the prior written authorisation of the company, is prohibited. The company can be contacted for all inquiries regarding the use of its products.
The company follows a policy of continuous product development and improvement and reserves the right to modify specifications, equipment and instructions regarding use and maintenance at any time, without notice.

Declaration of conformity

We declare under our own responsibility that the below equipment complies in all parts with the CEE and EN directives.
The declaration of conformity is enclosed to the technical booklet enclosed with the unit. The unit contains fluorinated greenhouse gases.

TABLE OF CONTENTS

1 Introduction

1.1	Preliminary information	6
1.2	Purpose and content of the instructions	6
1.3	Keeping the instructions	6
1.4	Updating the instructions	6
1.5	How to use these instructions	6
1.6	Residual risks	7
1.7	General information on safety symbols	7
1.8	Safety symbols used	8
1.9	Limits of use and non-permitted uses	8
1.10	Identification of the unit	9

2 Safety

2.1	Warnings on potentially dangerous toxic substances	10
2.2	Handling	10
2.3	Prevent the inhalation of high vapour concentrations	10
2.4	Procedures in case of accidental refrigerant leakage	10
2.5	Main toxicological information on the type of refrigerant used	11
2.6	First Aid measures	11

3 Technical characteristics

3.1	Unit description	12
3.2	Versions available	13
3.3	Description of accessories	14
3.4	Technical data	16
3.5	Use limits	19
3.6	Compressor partialisation steps	20
3.7	Correction factors	20
3.8	Sound data	21

4 Installation

4.1	General warnings and use of symbols	22
4.2	Health and safety of workers	22
4.3	Personal protection devices	22
4.4	Receipt and inspection	23
4.5	Storage	23
4.6	Unpacking	24
4.7	Lifting and handling	24
4.8	Positioning and minimum technical spaces	25
4.9	Hydraulic connections	26
4.10	Chemical characteristics of the water	27
4.11	Position connections	28
4.12	Plant connection	28
4.13	Domestic hot water connection	29
4.14	Source side connection	29
4.15	Minimum water content of utility /sanitary circuit	31
4.16	Hydraulic circuit filling	31
4.17	Emptying the system	31
4.18	Typical installations	32
4.19	Electrical connections: preliminary safety information	33
4.20	Electrical data	34
4.21	Electrical connections	34
4.22	Principle cooling layouts	39

5 Start-up

5.1	Preliminary checks	40
5.2	Operating characteristics	41
5.3	Control panel	42
5.4	Procedures	43

6 Utility use

6.1	Main functions	44
6.2	User pages display	45

7	Unit maintenance	
7.1	General warnings	46
7.2	Access to the unit	46
7.3	Scheduled maintenance	47
7.4	Periodic and initial start-up checks	47
7.5	Cooling circuit repair	49
8	Decommissioning	
8.1	Disconnecting the unit	50
8.2	Decommissioning, disposal and recycling	50
8.3	WEEE Directive (EU only)	50
9	Diagnosis and troubleshooting	
9.1	Troubleshooting	51
9.2	Possible anomalies and possible remedies	52

1.1 PRELIMINARY INFORMATION

The reproduction, storage and transmission, even partial, of this publication in any form without the prior written authorisation of the Company is prohibited.

The machine, to which these instructions refer, has been designed for the uses that will be presented in the specific paragraphs, compatibly with its performance characteristics. Any contractual or non-contractual liability of the Company is excluded for damage caused to persons, animals or property, installation errors, adjustment and maintenance or for improper use. All uses not expressly indicated in this manual are not permitted.

This documentation provides informational support and cannot be considered as a contract with third parties.

The Company implements a policy of improvement and constant development of its products. It therefore reserves the right to make changes to the specifications, set-ups and documentation at any time, without notice and without having to update what has already been delivered.

1.2 PURPOSE AND CONTENT OF THE INSTRUCTIONS

These instructions are intended to provide essential information for the selection, installation, use and maintenance of the machine. They have been prepared in compliance with the legislative provisions issued by the European Union and with the technical regulations in force on the date of issuing of the instructions themselves.

The instructions include instructions for avoiding reasonably foreseeable improper use.

1.3 KEEPING THE INSTRUCTIONS

The instructions must be placed in a suitable place, away from dust, humidity and must be easily accessible to users and operators.

The instructions must always accompany the machine throughout its life cycle and must therefore be transferred to any subsequent user.

1.4 UPDATING THE INSTRUCTIONS

It is advisable to always check that the instructions are updated to the latest revision available.

Any updates sent to the customer must be kept as an annex to this manual.

The Company is available to provide any information regarding the use of its products.

1.5 HOW TO USE THESE INSTRUCTIONS



The instructions are an integral part of the machine.

Users or operators must consult the instructions before any operation on the machine and in any case of uncertainty regarding transportation, handling, installation, maintenance, use and dismantling of the machine.

In these instructions, to draw the attention of the operators and users to the operations to be carried out in safety, the graphic symbols reported in the following paragraphs have been inserted.

1.6 RESIDUAL RISKS

The machine was designed to minimise the risks to the safety of those persons who will interact with it. During the project it was not technically possible to completely eliminate the causes of risk. Therefore it is absolutely necessary to refer to the following instructions and symbols.

PARTS CONSIDERED	RESIDUAL RISK	MODES	PRECAUTIONS
Inside the unit: compressors and gas delivery pipes.	Burns	Contact	Avoid contact, use protective gloves.
Inside the unit: electrical cables and metal parts.	Electrocution, severe burns.	Insulation fault of power supply cables, live metal parts.	Adequate electrical protection of the supply lines; utmost care in making the earthing connection of the metal parts.
Outside of the unit: area around the unit.	Intoxications, severe burns.	Fire due to short circuit or overheating of the supply line upstream of the unit's electrical panel.	Section of the cables and protection system of the power supply line complying with the standards in force.
High pressure safety valve.	Intoxications, severe burns, hearing loss.	Intervention of the high pressure safety valve with the compartment of the cooling circuit open.	Avoid opening the refrigeration circuit compartment as much as possible; carefully check the condensing pressure value; use all the personal protection equipment required by law. PPE must also protect against gas leakage from the safety valve. The discharge of these valves is directed to avoid causing damage to persons or property.
Entire unit	Bursting or exploding, injuries, burns, poisoning due to external fire.	Fire due to natural disasters or the combustion of elements adjacent to the unit.	Prepare the necessary fire-fighting equipment and/or adequate signs indicating that the unit is under pressure.
Entire unit	Bursting or exploding, injuries, burns, poisoning, electrocution due to natural disasters or earthquake.	Breakage, failure due to natural disasters or earthquake	Prepare the necessary precautions, both electrical (adequate differential thermal breaker and electrical protection of the power supply lines; maximum care in making the earth connection of the metal parts), and mechanical (for example, dedicated anti-seismic anchors or anti-vibration mountings to prevent breakage or accidental falls)

1.7 GENERAL INFORMATION ON SAFETY SYMBOLS

Individual safety symbols in accordance with ISO 3864-2:



PROHIBITION

A black symbol inserted in a red circle with a red diagonal indicates an action that must not be performed.



WARNING

A black graphic symbol inserted in a yellow triangle with black borders indicates a danger.



COMPULSORY ACTION

A white symbol inserted in a blue circle indicates an action that must be performed to avoid a risk.

Combined safety symbols in accordance with ISO 3864-2:



The graphic warning symbol is completed with additional safety information (text or other symbols).

1.8 SAFETY SYMBOLS USED



GENERIC DANGER

Strictly observe all the indications next to the pictogram. Failure to follow the instructions can generate risk situations with possible consequent damage to the health of the operator and of the user in general.



ELECTRICAL HAZARD

Strictly observe all the indications next to the pictogram.
The symbol indicates machine components or, in this manual, identifies actions that could generate electrical hazards.



MOVING PARTS

The symbol indicates moving machine components that could generate risks.



HOT SURFACES

The symbol indicates components of the machine with a high surface temperature that could generate risks.



CUTTING SURFACES

The symbol indicates components or parts of the machine that could cause cutting injuries upon contact.



GROUND CONNECTION

The symbol identifies the point of the machine for grounding.



READ AND UNDERSTAND THE INSTRUCTIONS

Read and understand the machine instructions before performing any operation.



RECOVERABLE OR RECYCLABLE MATERIAL

1.9 LIMITS OF USE AND NON-PERMITTED USES

The machine has been designed and built exclusively for the uses described in the paragraph "Limits of use" of the technical manual. Any other use is prohibited as it could generate risks for the health of operators and users.



However, the unit is not suitable to be operated in environments:

- With potentially explosive or excessively dusty atmospheres;
- Where vibrations are present;
- Where there are electromagnetic fields;
- In which aggressive atmospheres are present;
- Outdoors.

1.10 IDENTIFICATION OF THE UNIT

Each unit is equipped with an identification plate that shows the main information of the machine. The data on the plate may differ from that shown in the technical manual as the latter contains the data of the standard units without accessories. For electrical information not present on the label, refer to the wiring diagram. A fac-simile of a plate is shown below.

		Manufacturer: PD322111			
Modello Model		123456 Matricola Serial number			
2 Categoria PED PED Category		3/2017 Data di fabbricazione Manufacture date			
R410A Tipo refrigerante Refrigerant type		2 Gruppo fluido Fluid group		2088 GWP	
c1 Kg Carica refrigerante Refrigerant charge		c2 Kg Carica refrigerante Refrigerant charge		CO₂ Equivalente CO ₂ Equivalente	
400V-3ph+N-50Hz Tensione-Fasi-Frequenza Voltage-Phases-Frequency		F.L.A. (A)		F.L.I. (kW)	
LATO BASSA PRESSIONE LOW PRESSURE SIDE			LATO ALTA PRESSIONE HIGH PRESSURE SIDE		
bar PS			bar PS		
Min -30 °C Temperatura di progetto Design temperature		Max +130 °C Temperatura di progetto Design temperature		Min -30 °C Temperatura di progetto Design temperature	
Max +130 °C Temperatura di progetto Design temperature					
Peso a vuoto Weight					
Contiene gas fluorurati ad effetto serra disciplinati dal protocollo di Kyoto Contains fluorinated greenhouse gasses covered by the Kyoto protocol					



The identification label must never be removed from the unit.

2.1 WARNINGS ON POTENTIALLY DANGEROUS TOXIC SUBSTANCES

2.1.1 Identification of the type of fluid used: R410A

- Difluoromethane (HFC-32) 50% by weight CAS No.: 000075-10-5
- Pentafluoroethane (HFC-125) 50% by weight CAS No.: 000354-33-6

2.1.2 Identification of the type of oil used

The lubricating oil used in the cooling circuit of the unit is of the polyester type. In any case, always refer to what is indicated on the compressor plate.



For any further information regarding the characteristics of the refrigerating fluid and oil used, refer to the safety data sheets available from the manufacturers of refrigerant and lubricating oils.

Main Ecological Information on the refrigerants used.



ENVIRONMENTAL PROTECTION: Carefully read the ecological information and the following instructions.

2.1.3 Persistence and degradation

The refrigerating fluids used decompose in the lower atmosphere (troposphere) relatively quickly. The decomposed products are highly dispersible and therefore have a very low concentration. They have no influence on photochemical smog, meaning that they are not one of the VOC volatile organic compounds (as established by the guidelines of the UNECE agreement). R410A refrigerants (R32 and R125) do not damage the ozone layer. These substances are regulated by the Montreal protocol (1992 revision) and by EC regulation no. 2037/200 dated 29 June 2000.

2.1.4 Effects on effluent treatment

Discharges into the atmosphere of these products do not cause long-term water contamination.

2.1.5 Exposure control and individual protection

Use protective clothing and gloves; always protect the eyes and face.

2.1.6 Occupational exposure limits

HFC-32	TWA 1000 ppm
HFC-125	TWA 1000 ppm

2.2 HANDLING



Users and maintenance personnel must be adequately informed about the risks due to the handling of potentially toxic substances. Failure to observe the above instructions may cause personal injury or damage the unit.

2.3 PREVENT THE INHALATION OF HIGH VAPOUR CONCENTRATIONS

Atmospheric concentrations of refrigerant must be kept to a minimum and kept as low as possible, below the occupational exposure limit. Vapours are heavier than air, and dangerous concentrations can form near the ground, where general ventilation is poor. In this case, ensure adequate ventilation. Avoid contact with naked flames and hot surfaces, because toxic and irritating decomposition products can be formed. Avoid contact between the liquid and the eyes or skin.

2.4 PROCEDURES IN CASE OF ACCIDENTAL REFRIGERANT LEAKAGE

Ensure adequate personal protection (using means of respiratory protection) during cleaning operations.

If the conditions are sufficiently safe, isolate the source of the leak. If the amount of the leak is limited, allow the material to evaporate provided that adequate ventilation is ensured. If the leak is significant, adequately ventilate the area.

Contain spilled material with sand, earth or other suitable absorbent material.

Prevent the refrigerant from entering drains, sewers, basements or work holes, because suffocating vapours can form.

2.5 MAIN TOXICOLOGICAL INFORMATION ON THE TYPE OF REFRIGERANT USED

2.5.1 Inhalation

A high atmospheric concentration can cause anaesthetic effects with possible loss of consciousness. Prolonged exposures can cause abnormal heart rhythms and sudden death. Higher concentrations can cause asphyxia due to the reduced oxygen content in the atmosphere.

2.5.2 Contact with the skin

Splashes of sprayed liquid can cause frost burns. It is unlikely to be dangerous due to skin absorption. Prolonged or repeated contact may cause removal of skin fat, resulting in dryness, cracking and dermatitis.

2.5.3 Eye contact

Splashes of sprayed liquid can cause frost burns.

2.5.4 Ingestion

Although highly unlikely, it can cause frost burns.

2.6 FIRST AID MEASURES



Strictly follow the warnings and first aid procedures below.

2.6.1 Inhalation

Remove the victim from the source of exposure, keep them warm and at rest. Administer oxygen if necessary. Give artificial respiration if breathing has stopped or shows signs of stopping. If there is cardiac arrest perform external cardiac massage. Request medical assistance.

2.6.2 Contact with the skin

In case of contact with the skin, wash immediately with warm water. Thaw the epidermal tissue with water. Remove contaminated clothing. Clothing can stick to the skin in case of frost burns. If there is irritation or blistering, seek medical assistance.

2.6.3 Eye contact

Wash immediately with eye wash or with clean water, keep eyelids open for at least ten minutes. Request medical assistance.

2.6.4 Ingestion

Do not induce vomiting. If the injured person is conscious, rinse the mouth with water and administer 200-300 ml of water to be drunk. Request medical assistance.

2.6.5 Further medical treatment

Symptomatic treatment and supportive therapy as indicated. Do not administer adrenaline and sympathomimetic drugs following exposure, due to the risk of cardiac arrhythmia.

3.1 UNIT DESCRIPTION

The series heat pumps are particularly suitable for use in groundwater or geothermal probes. These units find their ideal application in combination with radiant panel heating systems or in all situations in which maximum efficiency is required in heating mode. The units have been designed to have an extremely efficient heating performance and can operate with a water temperature of up to 60°C.

The units are available in various versions both in the 2-pipe configuration on the utility side and in the 4-pipe configuration on the utility side. All versions are able to produce domestic hot water; the 2-pipe versions through the activation of an external 3-way valve, the 4-pipe versions using a dedicated hydraulic circuit used for domestic hot water which allows its production regardless of the unit's operating mode. The available versions and the wide range of accessories make it possible to identify the model and the most suitable solution for the type of system served.

3.1.1 Carpentry

All units are produced in hot-dip galvanised sheet metal and painted with polyurethane powders in the oven at 180°C to ensure the best resistance to atmospheric agents. The carpentry is self-supporting with removable panels to facilitate inspection and maintenance of the internal components.

3.1.2 Cooling circuit

The refrigerant gas used in these units is R410A. The refrigeration circuit is created using components from leading international companies and according to the regulations concerning the brazing and welding processes.

The cooling circuit includes: filter drier, electronic thermostatic valve, cycle reversing valve, Schrader valves for maintenance and control and a safety device (according to the PED regulation).

3.1.3 Compressor

The compressors are of the scroll type, optimised for heating applications with a particular structure that offers high efficiencies especially when the source temperature is low. The compressors are supplied with a thermal protection relay embedded in the electric windings. Inspection of the compressors is possible through the front panel of the unit which allows maintenance even with the units in operation.

3.1.4 Source exchanger

The source side exchangers, with braze-welded plates, are made of AISI 316 stainless steel. They are of the single circuit type. Use of this type of heat exchangers greatly reduces the refrigerant charge of the unit compared to traditional shell and tube evaporators, and increases its cooling capacity. The exchangers are insulated in the factory using closed cell material and are protected by a temperature probe used as an antifreeze protection probe.

3.1.6 Utility exchangers

The utility side exchangers are made of braze welded plates and AISI 316 stainless steel. They are of the single circuit type. All units are equipped with a "sub-cooler" to increase the efficiency of the refrigeration cycle. The exchangers are insulated in the factory using closed cell material.

3.1.7 Electrical panel

The electrical panel is made in compliance with the European standards EN60204. Access to the electrical panel is possible by removing the front panel of the panel, being sure to position the main door interlock switch in the OFF position. The following components are also present as standard: Main switch, thermomagnetic circuit breakers to protect the compressors and fuses to protect the pumps and auxiliary circuits, compressor relay and pump relay. The panel is also equipped with a terminal board with a configurable digital input and voltage-free digital outputs.

3.1.8 Microprocessor

All units are equipped with microprocessor control. The microprocessor controls the following functions: water temperature regulation, antifreeze protection, compressor timing, compressor start-up sequence, alarm reset, alarm management and operation LED. On request the microprocessor can be connected to remote BMS control systems. The technical office is available to study, together with the customer, different solutions using the most popular communication protocols.

3.1.9 Control and Protection Devices

All the units are supplied as standard with the following control and protection devices: supply water temperature probes on source side heat exchanger and on utility side heat exchanger, manual reset high pressure switch, compressor uniperometric protection, pump thermal protection, high and low pressure transducers, source circuit and utility circuit differential pressure switch.

3.1.10 Hydraulic kit

The units are equipped with a hydraulic kit consisting of the following:

- utility circuit: variable speed circulation pump, expansion vessel (on some models), water flow sensor (differential pressure switch), connection for filling and draining water;
- source circuit: variable speed circulation pump (or modulating two-way valve, for the well version) regulated by the microprocessor to optimise the operating conditions of the cooling circuit, expansion vessel (on some models), water flow sensor (pressure switch differential for the probe and flow switch version - to be installed on site - for the well version), connection for filling and draining water;
- sanitary circuit (for the R version): variable speed circulation pump regulated by the microprocessor to maximise the recovery of condensation heat.

3.1.11 Electronic thermostatic valve

All the units are equipped with an electronic thermostatic valve, in order to optimise the functioning of the cooling circuit and to maximise the energy efficiency of the system in all operating conditions that can be implemented on the system.

3.2 VERSIONS AVAILABLE

All units are hot/cold reversible, with cycle inversion on the cooling circuit.

3.2.1 Version (without heat recovery)

The units in this version are equipped with a single heat exchanger on the utility side to produce hot water in heating operation or chilled water in cooling operation (the two operating modes are alternatives to each other). The unit must be installed on a "two-pipe" type system.

3.2.2 Version with domestic hot water diverter valve management

The units in the version without heat recovery can be configured to manage a diverter valve to heat a storage tank to be used for the production of domestic hot water. In this way, in each of the operating modes described above, if the temperature in the domestic hot water storage tank falls below a selected value, the unit will be set up to bring it back to the determined set value, positioning the diverter valve appropriately. This operating mode is a priority and an alternative to operation for the utility (in heating or cooling).

The unit must be installed on a "two-pipe" type system; a three-way diverter valve (not included in the machine) must be installed on the unit's outlet connection for heating of the domestic hot water storage tank.

The configuration of the control to manage the diverter valve should be performed in the factory and as such it is necessary to communicate this requirement during the order phase.

3.2.3 Version /P4S (with total heat recovery)

The units in the version with total heat recovery, in addition to the one on the utility side, are equipped with an additional heat exchanger dedicated to domestic hot water heating. This exchanger is installed on the compressor discharge line, upstream of the cycle reversing valve, through which the high pressure and temperature refrigerant passes both in heating and in cooling operation; this exchanger is sized in such a way as to completely dissipate the condensation heat of the refrigeration circuit.

Thanks to this component, the units in version /R can perform all the functions described in the previous paragraph, but with some considerable advantages. Firstly, if the conditions exist to do this, it is possible to transfer to the storage of heat recovered by the domestic hot water exchanger while the unit is operating in heating or cooling mode. Furthermore, when switching from cooling to domestic hot water operation or vice-versa, there will be no mixing of water at different temperatures between the utility circuit and the sanitary circuit, as in the case of the diverter valve. The unit must be installed on a "four-pipe" type system (two for the utility circuit and two for the domestic hot water circuit - in this case, the two circuits are completely separate). If the temperature in the domestic hot water storage tank falls below a selected value, the unit will be set to return it to the determined set value, transferring heat through the dedicated exchanger. In heating mode, if the necessary conditions exist, the unit will simultaneously transfer high-temperature heat to the domestic water storage and heat to a temperature below the utility circuit; in this case, the advantage is to transfer the share of heat at high temperature to an efficiency comparable with that of low temperature heating. In cooling mode, if the necessary conditions exist, the unit will extract heat from the utility circuit and transfer it, as far as possible, to the sanitary circuit, disposing of the remainder in the source; in this case the heat transferred to the sanitary circuit is produced completely free, as, if it were not recovered, it would be dissipated in source.

In both cases, the heat recovery mechanism can occur even if the temperature in the domestic hot water storage has reached the set point; this is why it is not uncommon for the domestic hot water storage to be found at temperatures above the set temperature.

The sanitary exchanger circuit must be created by providing an expansion vessel, a safety valve, a filling and discharge connection (not included in the unit).

3.3 DESCRIPTION OF ACCESSORIES

3.3.1 Rubber vibration dampers (KAVG)

To be installed beneath the unit base and the ground to avoid the transmission of vibrations (and the noise) to the building.

3.3.2 RS485 serial interface card modbus protocol (INSE)

This controller card enables the controller to communicate with other devices on a BMS using Modbus protocol. In units where it is optional, it would be a kit that is supplied separately.

3.3.3 Electronic soft starter (DSSE)

The soft starter reduces the peak starting current down to a maximum of 40% of the nominal peak value. The device can only be installed in the factory.

3.3.4 Remote control panel (PCRL)

All units are supplied with microprocessor control panel with high definition display, mounted on board of the unit and it is remotable up to 50 mt. distance.

3.3.5 Low noise version (LS00)

This version includes the complete acoustic insulation of the unit with compressor jackets and insulating material made with high density media and the interposition of heavy bitumen layer.

WZA - WZA/RV		06	08	12	16	20	24	33	40
Main switch		●	●	●	●	●	●	●	●
Microprocessor control		●	●	●	●	●	●	●	●
Water pumps		●	●	●	●	●	●	●	●
LS low noise version	LS00	○	○	○	○	○	○	○	○
Electronic soft starter	DSSE	--	--	--	○	○	○	○	○
Rubber anti-vibration mounts	KAVG	●	●	●	●	●	●	●	●
Remote control panel	PCRL	○	○	○	○	○	○	○	○
Serial interface card RS485	INSE	○	○	○	○	○	○	○	○

● STANDARD
 ○ OPTIONAL
 -- NOT AVAILABLE

3.4 TECHNICAL DATA

WZA Model		06	08	12	16	20	24	33	40
Winter operation (1)									
Heat output	kW	7,7	9,9	13,6	17,2	22,8	26,9	34,0	44,7
compressor power consumption	kW	1,3	1,6	2,1	2,7	3,8	4,3	5,6	7,7
COP	W/W	5,89	6,06	6,26	6,18	6,01	6,13	6,06	5,77
System side									
System water flow rate	m ³ /h	0,991	1,30	1,75	2,26	2,93	3,61	4,37	5,81
Useful head (pressure drop for HFS)	kPa	65	62	58	50	67	60	110	80
Pump power consumption	W	70	70	70	70	140	140	310	310
Geothermal side									
Cooling capacity to be exchanged in the probe	kW	4,52	5,97	8,10	10,5	13,5	16,0	20,2	26,0
Probe fluid flow rate	m ³ /h	1,35	1,78	2,41	3,12	4,02	4,76	6,02	7,74
Useful head (pressure drop for HFS)	kPa	59	55	89	61	51	41	87	48
Pump power consumption	W	70	70	140	140	140	140	310	310
DHW Side (4)									
Heat output	kW	5,35	7,00	9,42	12,2	15,8	19,5	23,6	31,8
compressor power consumption	kW	1,86	2,37	3,11	4,10	5,32	6,25	7,92	10,4
DHW flow rate	m ³ /h	0,920	1,20	1,62	2,10	2,72	3,35	4,06	5,47
Useful head (pressure drop for HFS)	kPa	66	62	57	55	41	52	53	90
Pump power consumption	W	70	70	70	70	70	140	140	140
Winter operation (2)									
Heat output	kW	7,40	9,69	13,0	16,4	21,8	25,6	32,8	42,3
compressor power consumption	kW	1,29	1,62	2,16	2,77	3,78	4,36	5,56	7,77
COP	W/W	5,74	5,98	6,02	5,92	5,77	5,87	5,90	5,44
System side									
System water flow rate	m ³ /h	1,27	1,67	2,24	2,82	3,75	4,40	5,64	7,28
Useful head (pressure drop for HFS)	kPa	59	56	49	37	54	46	88	65
Well side									
Cooling capacity to be exchanged in the well	kW	6,17	8,15	11,0	13,8	18,3	21,4	27,5	34,5
Well fluid flow rate	m ³ /h	1,06	1,40	1,88	2,37	3,14	3,68	4,73	5,94
Exchanger pressure drop	kPa	3	4	6	7	7	9	9	14
Summer operation (3)									
Cooling capacity	kW	5,5	7,1	9,9	12,6	16,7	19,8	25,3	33,4
compressor power consumption	kW	1,4	1,8	2,4	3,0	4,1	4,8	6,0	8,2
EER	W/W	3,78	3,88	4,14	4,16	4,06	4,13	4,16	4,04
System side									
System water flow rate	m ³ /h	1,63	2,14	2,85	3,59	4,73	5,62	7,16	8,18
Useful head (pressure drop for HFS)	kPa	58	50	37	30	33	33	66	45
Geothermal side									
Heat output to be exchanged in probe	kW	10,7	13,9	18,6	23,6	31,0	36,8	47,0	56,2
Probe fluid flow rate	m ³ /h	1,90	2,46	3,30	4,18	5,49	6,52	8,33	9,95
Useful head (pressure drop for HFS)	kPa	51	45	54	31	34	42	41	25

WZA Model		06	08	12	16	20	24	33	40
Energy efficiency (5)									
Energy class in low temperature	--	A++	A++	A++	A++	A++	A++	A++	A++
SCOP in low temperature	kWh/kWh	5,41	5,68	5,66	5,67	5,69	6,07	6,03	5,79
η_s , h at low temperature	%	208,4	219,2	218,3	218,8	219,7	234,8	233,0	223,4
Energy class at medium temperature	--	A++	A++	A++	A++	A++	A++	A++	A++
SCOP at medium temperature	kWh/kWh	4,21	4,31	4,38	4,44	4,39	4,80	4,82	4,69
η_s , h at medium temperature	%	160,5	164,4	167,1	169,6	167,6	184,1	184,9	179,4
Cooling circuit									
Compressor type	tipo	Scroll							
Number of compressors/cooling circuits	nr./nr.	1/1	1/1	1/1	1/1	1/1	2/1	2/1	2/1
Refrigerant / Global Warming Potential	Type/GWP	R410A / 2088							
Refrigerant charge (R version)	kg	2,2	2,2	2,9	2,9	4,6	4,6	5,0	5,5
Refrigerant charge in CO ₂ equivalent (R version)	t CO ₂ eq.	4,6	4,6	6,0	6,0	9,6	9,6	10,4	11,4
Other data									
Electrical power supply	V/Ph/Hz	230/1/50 400/3/50+N			400/3/50+N				
Maximum current consumption:	A (1 f)	15	19	25	--	--	--	--	--
	A (3 f)	7	8	10	12	16	18	23	30
Inrush current	A (1 f)	62	85	110	--	--	--	--	--
	A (3 f)	30	45	54	64	78	63	75	92
Dimensions (l x d x h)	mm	620 x 575 x 1.000		620 x 650 x 1.080			800 x 880 x 1.070		
Net weight	kg	146	153	169	195	215	262	302	320
hydraulic connection diameters	" G	1"					1"1/4		
Sound pressure at 1m (6)	dB(A)	48	49	50	52	54	56	60	62
Sound power (according to ISO 3744)	dB(A)	62	63	65	67	69	71	75	77

- (1) Performance in heating conditions (according to EN 14511)
Utility circuit: radiant system • °C 30/35 • In/Out
External circuit: geothermal probe with 20% propylene glycol mixture in water • °C 0/-3 • In/Out
- (2) Performance in heating conditions (according to EN 14511)
Utility circuit: radiant system • °C 30/35 • In/Out
External circuit: well water • °C 10/5 • In/Out
- (3) Cooling performance under the conditions (according to EN 14511)
Utility circuit: radiant system • °C 12/7 • In/Out
External circuit: geothermal probe with 20% propylene glycol mixture in water • °C 30/35 • In/Out
- (4) Production of domestic hot water under conditions
Utility circuit: domestic hot water storage • °C 40/50 • In/Out
External circuit: geothermal probe 20% mixture of glycoled water propylene glycol 20 % • °C 0/-3 • In/Out
- (5) Variable temperate climate (according to EU Regulation 811/2013)
- (6) Sound pressure level in open field at 1 m from the unit (according to ISO 3744)

3.4.1 Total electrical consumption

WZA	Electrical power supply (V-Ph-Hz)	Maximum values														
		Compressor					Geothermal pump		System pump		Domestic hot water pump		Total			
		F.L.I. (kW)	F.L.A. (A)	L.R.A. (A)	cosphi	L.R.A. (A)*	F.L.I. (kW)	F.L.A. (A)	F.L.I. (kW)	F.L.A. (A)	F.L.I. (kW)	F.L.A. (A)	F.L.I. (kW)	F.L.A. (A)	L.R.A. (A)	L.R.A. (A)*
06 M	230/1/50	2,7	13	60	0,91	36	0,07	0,58	0,07	0,58	0,07	0,58	2,9	15	62	38
08 M	230/1/50	3,6	17	83	0,91	50	0,07	0,58	0,07	0,58	0,07	0,58	3,8	19	85	52
12 M	230/1/50	4,8	23	108	0,91	65	0,14	1,1	0,07	0,58	0,07	0,58	5,1	25	110	67
06	400/3/50 + N	2,6	4,8	28	0,77	17	0,07	0,58	0,07	0,58	0,07	0,58	2,8	6,5	30	19
08	400/3/50 + N	3,3	6,2	43	0,77	26	0,07	0,58	0,07	0,58	0,07	0,58	3,5	7,9	45	28
12	400/3/50 + N	3,9	7,4	52	0,77	31	0,14	1,1	0,07	0,58	0,07	0,58	4,2	10	54	33
16	400/3/50 + N	5,2	10	62	0,77	37	0,14	1,1	0,07	0,58	0,07	0,58	5,5	12	64	39
20	400/3/50 + N	6,9	13	75	0,77	45	0,14	1,1	0,14	1,1	0,07	0,58	7,3	16	78	48
24	400/3/50 + N	3,9	7,4	52	0,77	31	0,14	1,1	0,14	1,1	0,14	1,1	8,3	18	63	42
33	400/3/50 + N	5,2	9,7	62	0,77	37	0,31	1,4	0,31	1,4	0,14	1,1	11	23	75	50
40	400/3/50 + N	6,9	13	75	0,77	45	0,31	1,4	0,31	1,4	0,14	1,1	15	30	92	62

F.L.A.: maximum current consumption.
L.R.A.: inrush current.

F.L.I.: maximum power consumption.
L.R.A.*: inrush current with soft starter.

Compressor: for units with two compressors, the data refers to the single compressor.

3.5 USE LIMITS

Heating

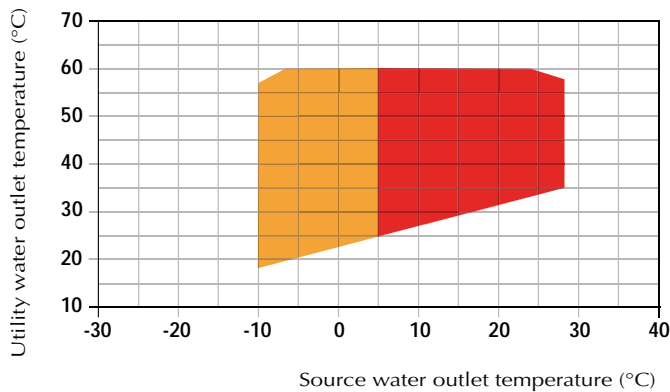

Cooling

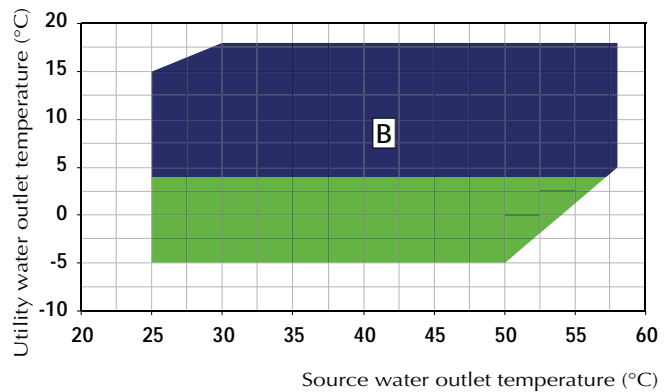

A With the addition of an adequate quantity of glycol in the source circuit

B With the addition of an adequate quantity of glycol in the utility circuit

3.5.1 Utility exchanger water flow rate

The nominal water flow refers to a temperature difference between input and output of the utility exchanger of 5°C. The maximum permissible flow rate is the one with a temperature difference of 3°C. Higher values can cause overly high pressure drops.

The minimum permitted water flow is the one with a temperature difference of 8°C.

Insufficient water flow rates can cause abnormal operating temperatures in the cooling circuit resulting in intervention of the safety devices and the unit stopping.

3.5.2 Utility hot water temperature (winter operation)

Once the system is fully operational, the temperature at the entrance to the utility and/or domestic hot water exchanger must not fall below 30°C; lower values can cause compressor malfunctions with the possibility of breakage.

The maximum outlet water temperature of the utility exchanger must not exceed 60°C. Otherwise the action of the safety devices stops the unit.

3.5.3 Chilled water temperature (summer operation)

The minimum temperature permitted at the utility heat exchanger outlet is 5°C; it is possible to produce water up to -5°C by adding an adequate quantity of glycol in the utility circuit. For lower temperatures the unit requires structural changes. In this case, contact our technical department. The maximum water temperature produced is 18°C.

3.5.4 Source water temperature

The minimum water outlet temperature from the source side exchanger (with glycolated water), in heating mode, is -20°C for sizes from 06 to 40 and -10°C for sizes from 60 to 100.



The appliances, in their standard configuration, are not suitable for installations in a saline environment.



The units are built according to the technical standards and safety rules in force in the European Community. The units have been exclusively designed for heating, air conditioning and domestic hot water (DHW) production and must be used for this purpose, compatibly with their performance characteristics. Any contractual or non-contractual liability of the Company is excluded for damage caused to persons, animals or property, installation errors, adjustment and maintenance or for improper use. All uses not expressly indicated in this manual are not permitted.



In case of operations outside of these values, please contact the Company.

3.6 COMPRESSOR PARTIALISATION STEPS

Model	NUMBER OF COMPRESSORS	
	1	2
06	100%	--
08	100%	--
12	100%	--
16	100%	--
20	100%	--
24	50%	50%
33	50%	50%
40	50%	50%

3.7 CORRECTION FACTORS

3.7.1 Glycol use correction factors

Percentage of ethylene glycol (%)	Freezing point (°C)	CCF	IPCF	WFCF	PDCF
0	0	1,00	1,00	1,00	1,00
10	-3.2	0,985	0,985	1,02	1,08
20	-7.8	0,980	0,990	1,04	1,12
30	-14.1	0,970	0,980	1,08	1,18
40	-22.3	0,960	0,970	1,14	1,25

CCF: Cooling capacity correction factor.
WFCF: Water flow rate correction factor.

IPCF: Power consumption correction factor.
PDCF: Pressure drop correction factor.

The correction factors of the water flow rate and the pressure drops must be applied to the values obtained without the use of glycol. The water flow rate correction factor is calculated in such a way as to maintain the same temperature difference that would be obtained without the use of glycol. The pressure drops correction factor is applied to the correct water flow value of the water flow correction factor.

3.7.2 Different correction factors t

Water temp. difference (°C)	3	5	8
CCCP	0,99	1	1,02
IPCF	0,99	1	1,01

CCCP = Power correction factor IPCF = Power consumption correction factor

3.7.3 Fouling factor different correction factors

Fouling factor	0.00005	0.0001	0.0002
CCCP	1	0,98	0,94
IPCF	1	0,98	0,95

CCCP = Power correction factor IPCF = Power consumption correction factor

3.8 SOUND DATA

SOUND LEVEL dB (A)										
Modello	63 Hz	125 Hz	250 Hz	500 Hz	1.000 Hz	2.000 Hz	4.000 Hz	8.000 Hz	Lp	Lw
06	47,0	5,0	10,0	28,0	37,0	32,0	37,0	34,0	48	62
08	48,0	1,0	12,0	29,0	32,0	31,0	39,0	31,0	49	63
12	49,0	6,0	13,0	32,0	35,0	34,0	40,0	33,0	50	65
16	51,0	5,0	14,0	32,0	35,0	32,0	39,0	32,0	52	67
20	53,0	6,0	15,0	33,0	39,0	37,0	43,0	36,0	54	69
24	55,0	6,0	16,0	34,0	35,0	39,0	45,0	38,0	56	71
33	59,0	13,0	33,0	40,0	43,0	40,0	47,0	40,0	60	75
42	61,0	14,0	23,0	41,0	47,0	45,0	51,0	44,0	62	77

Lp: sound power level calculated according to ISO 3744.

Lw: sound pressure level in free field at 1 m from the unit evaluated according to ISO 3744.

4.1 GENERAL WARNINGS AND USE OF SYMBOLS



Before carrying out any type of operation, each operator must be perfectly familiar with operation of the machine and its controls and must have read and understood all the information contained in this manual.



All operations performed on the machine must be carried out by qualified personnel in compliance with the national legislation in force in the destination country



The installation and maintenance of the machine must be carried out according to the national or local regulations in force.



Do not approach or insert any object into moving parts.

4.2 HEALTH AND SAFETY OF WORKERS



The operator's workplace must be kept clean, tidy and free from objects that could restrict free movement. The workplace must be adequately lit for the intended operations. Insufficient or excessive lighting can cause risks.



Ensure that excellent ventilation of the work rooms is always guaranteed and that the extraction systems are always functional, in an excellent condition and in compliance with the provisions of the law.

4.3 PERSONAL PROTECTION DEVICES



The operators who perform the installation and maintenance of the machine must have at their disposal and, when required, must wear the individual protection devices required by law listed below.



Protective footwear.



Eye protection.



Protection gloves.



Respiratory tract protection.



Hearing protection.

4.4 RECEIPT AND INSPECTION

When installing or servicing the unit, the rules indicated in this manual must be complied with, together with those on board the unit and, in any case, all necessary precautions must be taken. Failure to comply with these regulations may cause dangerous situations. On receiving the unit, check for any damage: the machine left the factory in perfect conditions; immediately report any signs of damage to the carrier and note them on the "Delivery Slip" before signing it. The Company must be informed, within 8 days, of the extent of the damage. The Customer must complete a written report in the event of significant damage.

Before accepting delivery, check:

- That the machine has not been damaged during transportation;
- That the delivered material corresponds to what is indicated in the transport document.

In case of damage or anomalies:

- Make a note of the damage immediately on the Delivery Sheet;
- Inform the supplier, within 8 days of receipt, of the extent of the damage. Reports after this deadline are not valid;
- In case of significant damage, complete a written report.

4.5 STORAGE

If it is necessary to store the unit, leave it packed indoors. If for some reason the machine is already unpacked follow the instructions below to prevent damage, corrosion and/or deterioration:

- Ensure that all openings are tightly closed and sealed;
- To clean the unit, never use steam or detergents that could damage it;
- Remove and entrust any keys needed to access the control panel to the site manager.

4.5.1 Transportation

Transportation must be performed by authorised carriers and the characteristics of the vehicle used must be such as not to damage the machine being transported/to be transported, either during loading and unloading or during transportation. If the roads to be driven on are uneven, the vehicle must be equipped with appropriate suspensions or internal bulkheads in order to avoid damaging the vehicle being transported in any way.



The maximum storage/transportation ambient temperature is +45°C and the minimum is -20°C.

4.6 UNPACKING



The packaging could be dangerous for operators.

It is advisable to leave the units packed during handling and to remove the packaging only at the time of installation. The unit's packaging must be removed carefully to avoid damaging the machine. The materials that compose the packaging can be of a mixed nature (wood, cardboard, nylon, etc.).

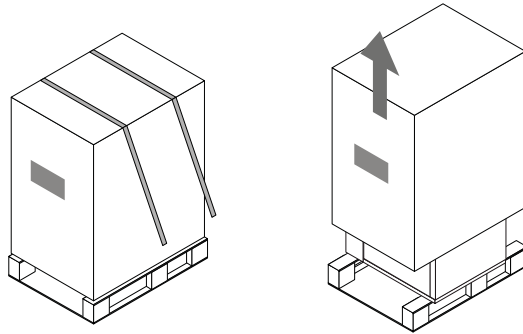

The packaging materials must be stored separately and delivered for disposal or possible recycling to the companies assigned to this purpose, thus reducing the environmental impact.

4.7 LIFTING AND HANDLING

Care must be taken when unloading and positioning the unit to avoid sudden or violent manoeuvres to protect the internal components. The units can be lifted with the aid of a forklift truck or, alternatively, by belts, being careful not to damage the side and top panels of the unit. The unit must always be kept horizontal during these operations.

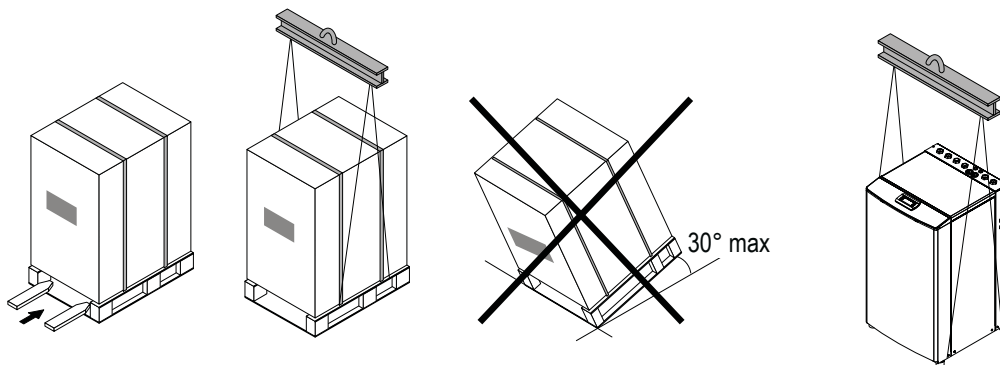

Use spacers to avoid damaging the unit.



During handling it is forbidden to exceed the maximum permitted inclination as indicated in the figure.

4.8 POSITIONING AND MINIMUM TECHNICAL SPACES

All models are designed and built for indoor installation; it is therefore absolutely necessary to avoid installing the unit outdoors. It is good practice to create a support slab of sizes appropriate to those of the unit. The units transmit a low level of vibrations to the ground; it is in any case advisable to place the antivibration supports between the base frame and the support surface. It is necessary to guarantee the minimum service spaces shown below to allow access during operation and maintenance.



The machine must be installed in a way that allows ordinary and extraordinary maintenance. The warranty does not cover costs related to platforms or handling equipment necessary for any repairs.



The place of installation must be chosen in accordance with the EN 378-1 and 378-3 standards. When choosing the installation site, all risks arising from accidental refrigerant leaks must be taken into consideration.

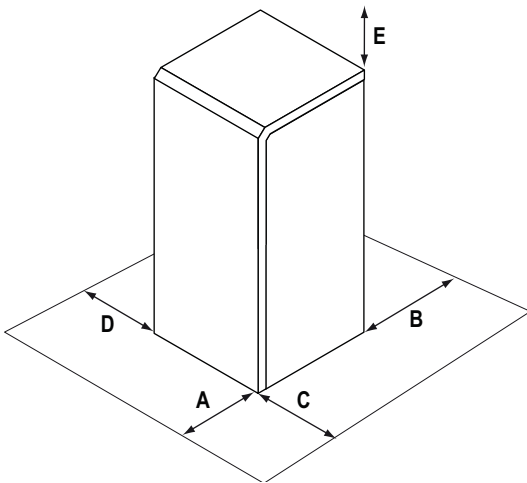

Mod.	A (mm)	B (mm)	C (mm)	D (mm)	E (mm)
06	500	20	400	400	600
08	500	20	400	400	600
12	500	20	400	400	600
16	500	20	400	400	600
20	500	20	400	400	600
24	600	20	600	600	600
33	600	20	600	600	600
40	600	20	600	600	600

4.9 HYDRAULIC CONNECTIONS

4.9.1 System side hydraulic connections

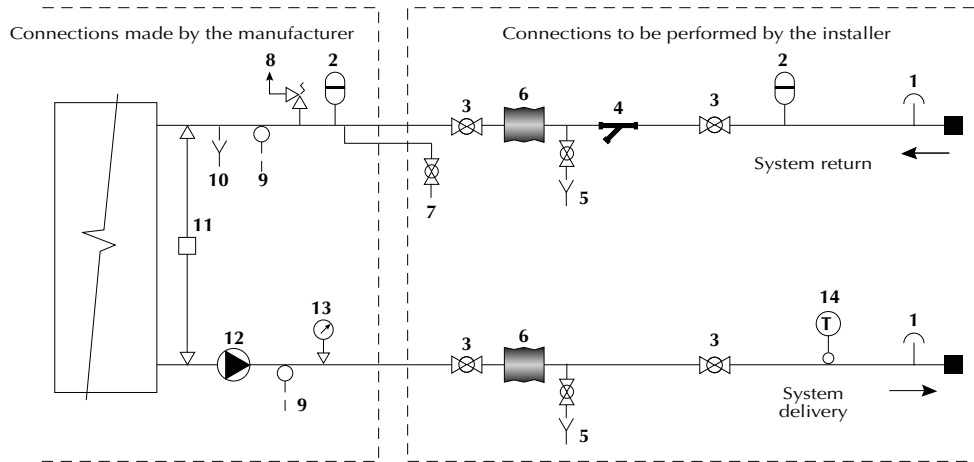

4.9.2 Domestic hot water side hydraulic connections

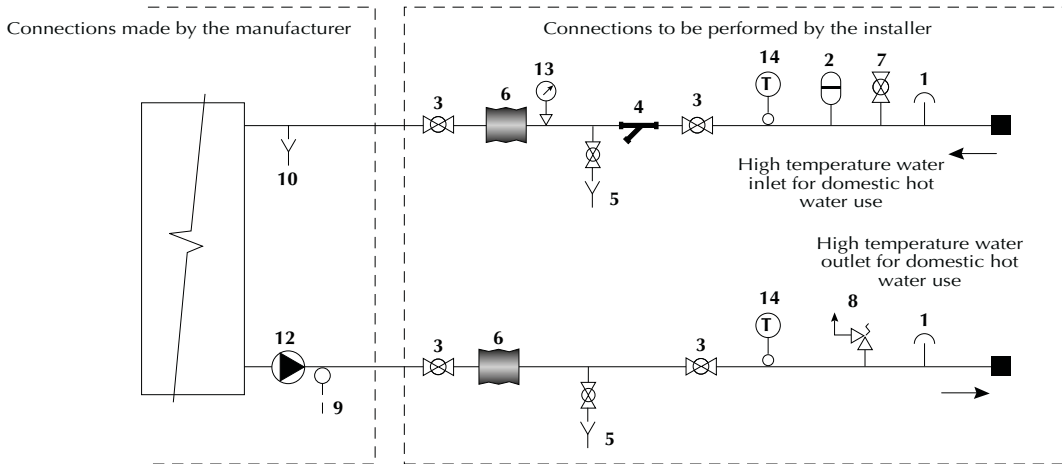

4.9.3 Geothermal side water connections

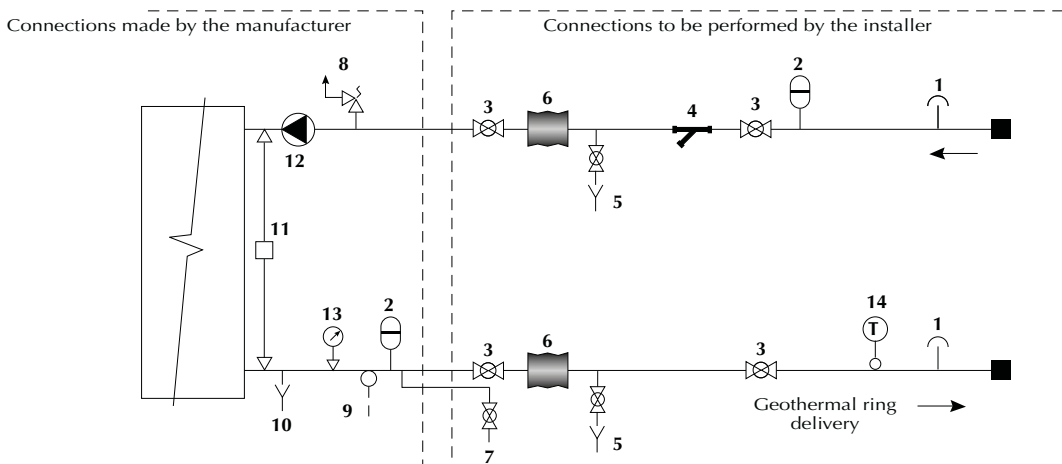

4.9.4 Well side hydraulic connections

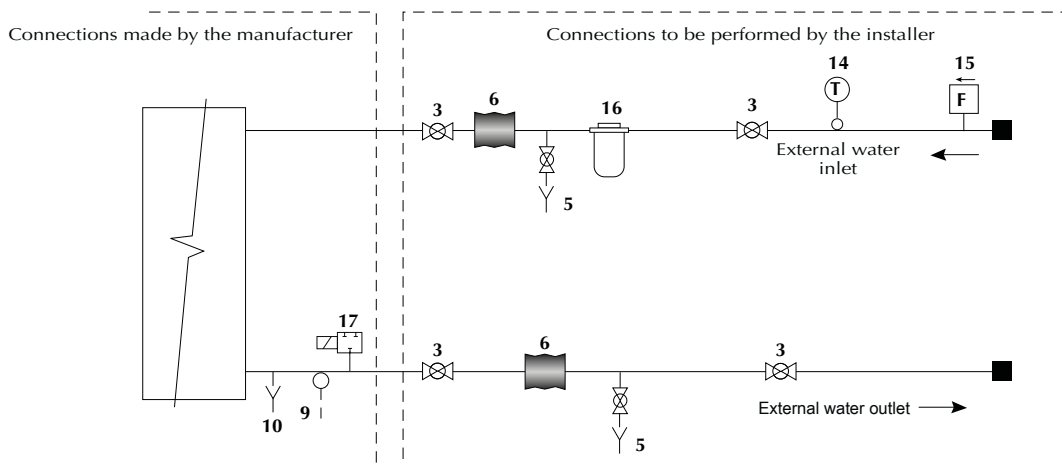

Ref.	Description	Ref.	Description
1	Vent valve	10	Discharge
2	Expansion vessel	11	Differential pressure switch
3	Cut-off valve	12	Circulation pump
4	Mesh filter (with a mesh not larger than 1 mm)	13	Pressure gauge
5	Drain valve	14	Thermometer
6	Antivibration element	15	Flow switch
7	Filler valve	16	Cartridge filter
8	Safety valve	17	Two-way modulating valve
9	Temperature probe		



It is compulsory to install on the USER WATER IN connection, a water strainer with a mesh not larger than 1 mm. Fitting this filter is COMPULSORY and the warranty will be invalidated if it is removed. The filter must be kept clean and checked periodically.

4.10 CHEMICAL CHARACTERISTICS OF THE WATER

Upon initial start-up the heat pump must be filled with clean water which should have the following characteristics:

PH	7-9	Total hardness	10÷30 °f
Electric conductivity	10÷500 µs/cm	Sulphur ions	Absent
Chlorine ions	<0,5 mg/l	Ammonia ions	Absent
Sulphuric acid ions	<0,05 mg/l	Silicon ions	Less than 30 mg/l
Ferrous residue	Less than 0.2 mg/l		



In the case of units operating with ground water (well version) it is necessary to periodically check the quality of the water available to exclude the fact that the fluid may be aggressive for the materials being used for the hydraulic circuit and the heat pump exchanger. It is also necessary to periodically check that the available water flow is not lower than the nominal one required for correct operation of the machine. If the two conditions mentioned above are not met, it is necessary to suspend use of the heat pump in order to avoid irreparable damage.

4.11 POSITION CONNECTIONS

4.11.1 Models 6-33

A	Geothermal supply
B	Geothermal return
C	Plant return
D	Plant flow
E	Geothermal load
F	Plant load
G	Sanitary supply
H	Sanitary return
I	Plant pressure gauge
L	Geothermal pressure gauge
M	Condensate drain

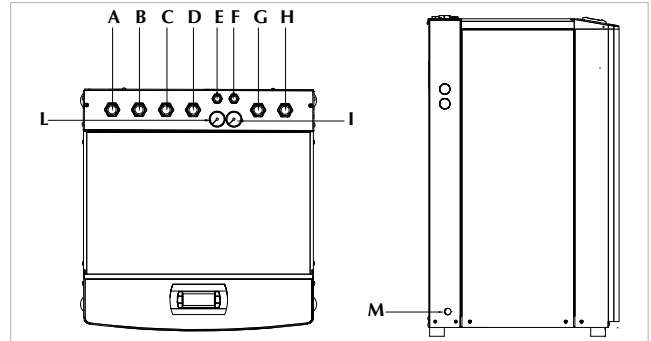

4.11.2 Model 40

A	GEO/R and GEO/R/P sanitary return 40>80
B	Sanitary flow
C	Plant return
D	Plant flow
E	Geothermal return / Well flow
F	Geothermal flow
G	Power supply
H	Well return
I	GEO/R and GEO/R/P 100 sanitary return

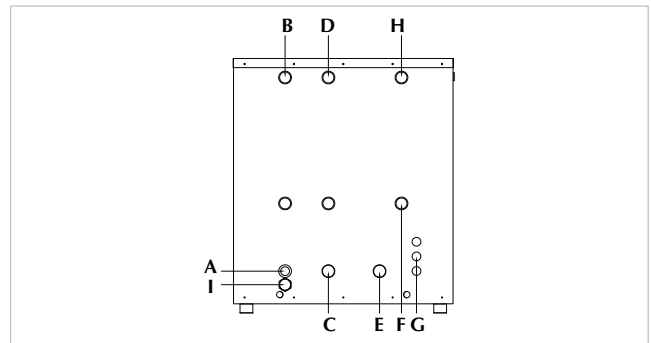

4.12 PLANT CONNECTION

4.12.1 Models 6-33

- Remove the protective caps from the connections.
- Connect the piping to the connections located on the upper side of the unit.
- Secure using the wrench-to-wrench system.
- Hemp and green paste are recommended for sealing.

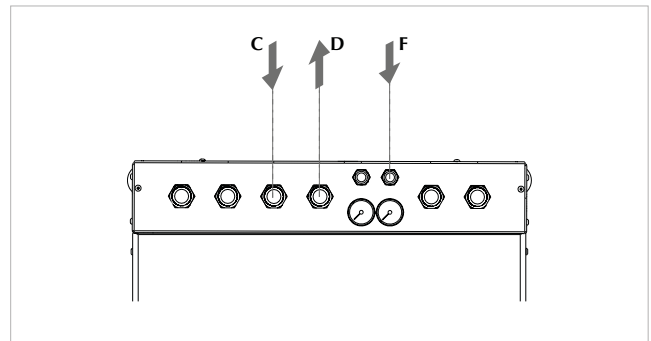

Provide on the connecting pipes shut-off taps and vibration-damping joints.

		6-8	12-16-20	24-33
C	Plant return	Ø 1"	Ø 1"	Ø 1" 1/4
D	Plant supply	Ø 1"	Ø 1"	Ø 1" 1/4
F	Plant load	Ø 1/2"	Ø 1/2"	Ø 1/2"

4.12.2 Model 40

- Remove the protective caps from the connections.
- Connect the piping to the connections located on the upper side of the unit.
- Secure using the wrench-to-wrench system.
- Hemp and green paste are recommended for sealing.

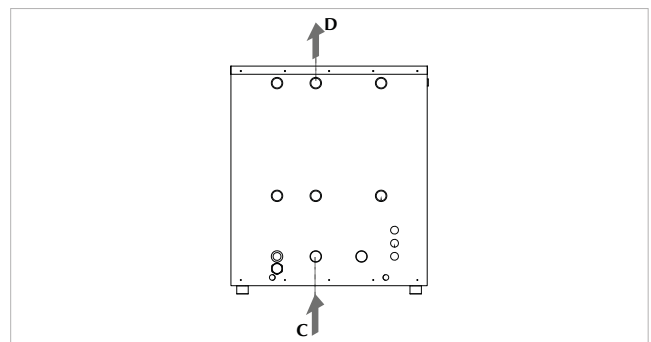

Provide on the connecting pipes shut-off taps and vibration-damping joints.

		40
C	Plant return	Ø 1" 1/2
D	Plant supply	Ø 1" 1/2

4.13 DOMESTIC HOT WATER CONNECTION

4.13.1 Models 6-33

- Remove the protective caps from the connections.
- Connect the piping to the connections located on the upper side of the unit.
- Secure using the wrench-to-wrench system.
- Hemp and green paste are recommended for sealing.



Provide on the connecting pipes shut-off taps and vibration-damping joints.



The installation of a properly sized expansion tank and a safety valve (6 bar) on the sanitary side is required.

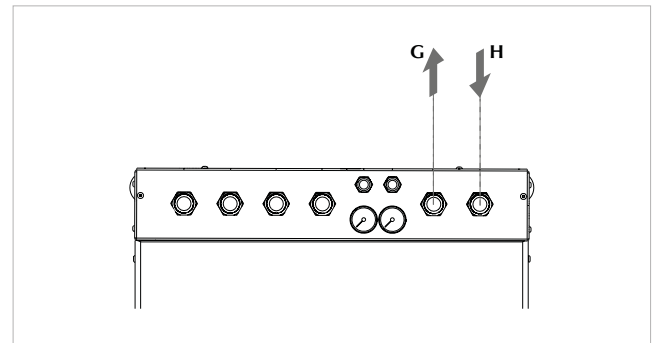

		6-8	12-16-20	24-33
G	Sanitary supply	Ø 1"	Ø 1"	Ø 1" 1/4
H	Sanitary return	Ø 1"	Ø 1"	Ø 1" 1/4

4.13.2 Model 40

- Remove the protective caps from the connections.
- Connect the piping to the connections located on the upper side of the unit.
- Secure using the wrench-to-wrench system.
- Hemp and green paste are recommended for sealing.



Provide on the connecting pipes shut-off taps and vibration-damping joints.



The installation of a properly sized expansion tank and a safety valve (6 bar) on the sanitary side is required.

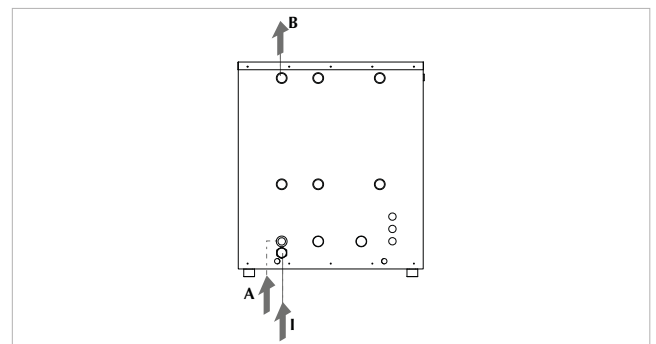

		40
A	Sanitary return	Ø 1" 1/2
I	Sanitary return	-
B	Sanitary supply	Ø 1" 1/2

4.14 SOURCE SIDE CONNECTION

4.14.1 Models 6-33

- Remove the protective caps from the connections.
- Connect the piping to the connections located on the upper side of the unit.
- Secure using the wrench-to-wrench system.
- Hemp and green paste are recommended for sealing.



Provide on the connecting pipes shut-off taps and vibration-damping joints.

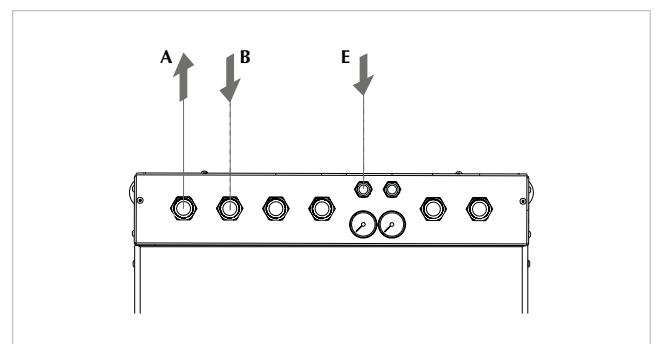

		6-8	12-16-20	24-33
A	Source supply	Ø 1"	Ø 1"	Ø 1" 1/4
B	Ritorno sorgente	Ø 1"	Ø 1"	Ø 1" 1/4
E	Geothermal load	Ø 1/2"	Ø 1/2"	Ø 1/2"

Geothermal



Where a geothermal probe is present, the water in the probe must be properly mixed with antifreeze liquid.

Well



It is mandatory to install a flow switch (supplied) and a filter, to protect the well side circuit, suitable for the water characteristics.



Verify that the well provides the flow rates necessary for the proper operation of the system.



It is necessary to ensure the water flow rate as stated, insufficient flow can cause freezing and subsequent rupture of the plate heat exchanger.



Refer to the wiring diagram in the “Technical Information” section for the electrical connection

4.14.2 Model 40

- Remove the protective caps from the connections.
- Connect the piping to the connections located on the upper side of the unit.
- Secure using the wrench-to-wrench system.
- Hemp and green paste are recommended for sealing.



Provide on the connecting pipes shut-off taps and vibration-damping joints.

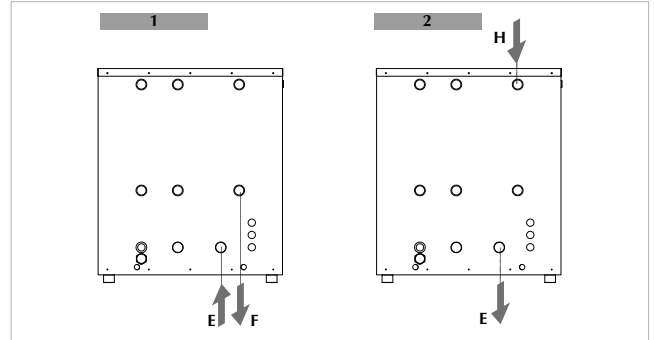

40		
E	Geothermal return/well delivery	Ø 1" 1/2
F	Geothermal supply	Ø 1" 1/2
H	Well return	Ø 1" 1/2
1	Geothermal connection	
2	Well connection	

Geothermal



Where a geothermal probe is present, the water in the probe must be properly mixed with antifreeze liquid.

Well



It is mandatory to install a flow switch (supplied) and a filter, to protect the well side circuit, suitable for the water characteristics.



it is necessary to ensure the water flow rate as stated, insufficient flow can cause freezing and subsequent rupture of the plate heat exchanger.



Verify that the well provides the flow rates necessary for the proper operation of the system.



Refer to the wiring diagram in the “Technical Information” section for the electrical connection

4.15 MINIMUM WATER CONTENT OF UTILITY /SANITARY CIRCUIT



The heat pump units require a minimum water content inside the utility/sanitary hydraulic circuit, in order to guarantee correct operation of the unit. Correct water content reduces the number of starts and stops of the compressors and therefore lengthens the operating life of the unit.
For these reasons it is necessary to guarantee the unit the following minimum water contents in the utility circuit:

Recommended minimum water content: 20 litres x heat output (kW) / number of compressors.

Model	06	08	12	16	20	24
Minimum water content (l)	150	200	280	340	450	270
Utility/source safety valve (bar)	3	3	3	3	3	3

Model	33	40
Minimum water content (l)	340	450
Utility/source safety valve (bar)	3	3



If the development of the utility and source circuits present differences in level of more than 10 m, it may be necessary to replace the safety valve inside the machine with a higher calibration pressure (**maximum 6 bar**).

4.16 HYDRAULIC CIRCUIT FILLING

- Before filling, check that all the discharge and drain valves are closed.
- Open all the vent valves on the pipes, inside the unit, and on the system terminals.
- Open all the shut-off valves.
- At the start of filling, slowly open the water valve of the filling group outside the unit.
- As the water begins to flow out of the vent valves, close them and continue filling the system until the water pressure gauge shows a pressure greater than 1.5 bar.

The system must be filled up to a pressure of between 1.5 and 2 bar. Ideally this operation be repeated after the machine has been in operation for a few hours (due to the presence of air bubbles inside the system). The system pressure must be regularly checked and if it falls below 1.5 bar it must be brought back to the initial value via the system filling valve. In this case, check the gaskets and seals of the hydraulic joints.

4.17 EMPTYING THE SYSTEM

- Before emptying, place the main switch in the "Off" position.
- Make sure the filling unit valve is closed.
- Open the drain valve external to the unit and all the vent valves of the system and terminals.



If the fluid in the hydraulic circuit contains antifreeze, it must not be released freely as it is a pollutant. It must be collected for possible re-use or to dispose of it in accordance with current regulations.

4.18 TYPICAL INSTALLATIONS

4.18.1 Typical system layout for heating, cooling and domestic hot water production

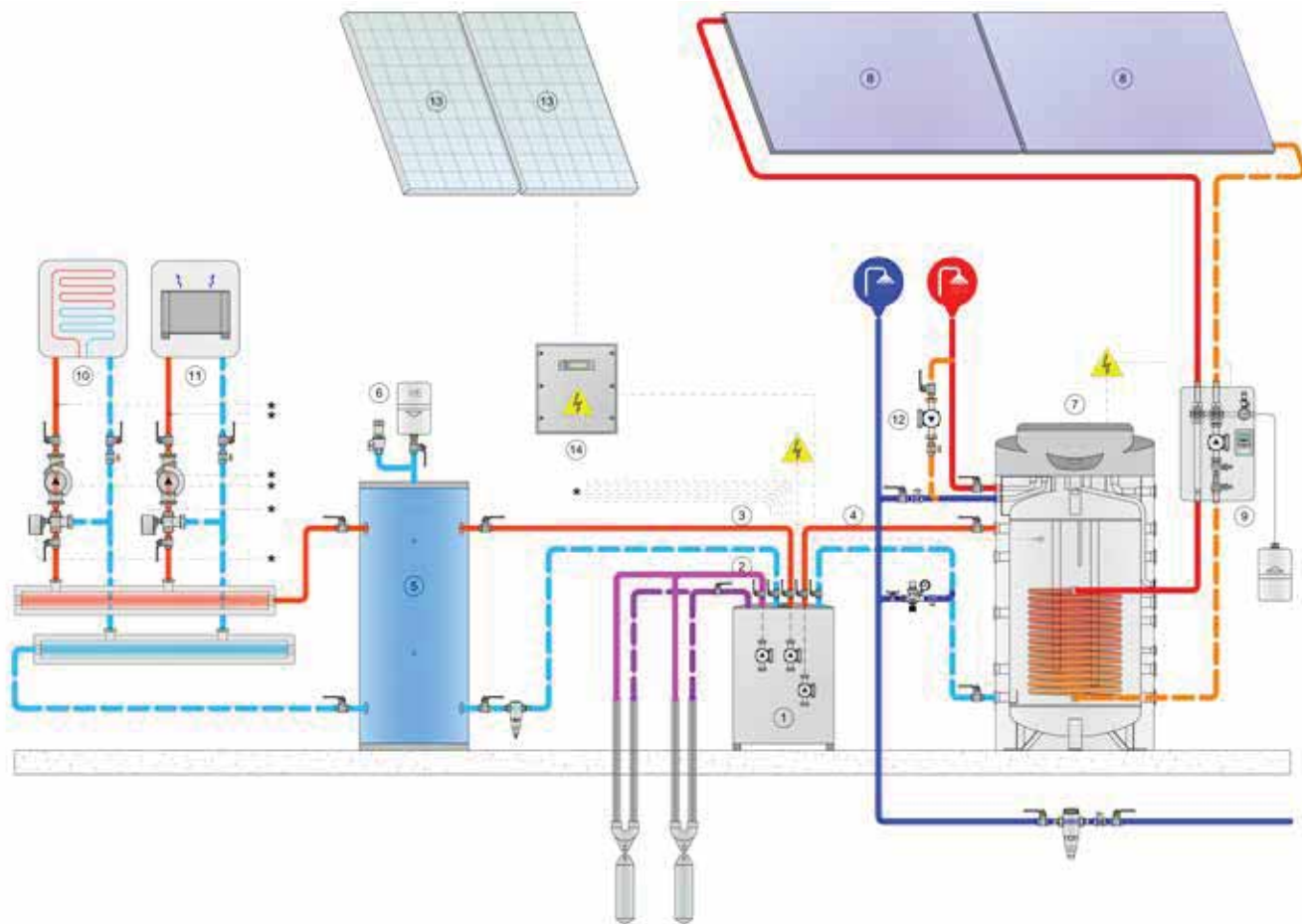

Ref.	Description	Ref.	Description
1	Heat pump (with recovery)	8	Thermal solar collectors
2	Geothermal circuit with inverter pump	9	Thermal solar pumping unit
3	System circuit with inverter pump	10	Radiant heating/cooling circuit with mixing valve
4	Sanitary circuit with inverter pump	11	Heating circuit 2
5	Inertial storage tank	12	Heating/cooling without mixing valve
6	Safety devices group	13	Photovoltaic modules
7	Instantaneous domestic hot water producer with thermal storage	14	Photovoltaic system inverter

4.19 ELECTRICAL CONNECTIONS: PRELIMINARY SAFETY INFORMATION

The electrical panel is located inside the unit in the upper part of the technical compartment where the refrigerating circuit components are located.

To access the electrical panel, remove the front panel of the unit.



The electrical connection must be made according to the wiring diagram attached to the unit and in compliance with local and international regulations.



Make sure that the power supply line of the unit is sectioned upstream of it.
Make sure that the disconnecting device is padlocked or that a dedicated warning sign is applied to the operating handle.



Check that the power supply corresponds to the nominal data of the machine (voltage, phases, frequency) shown on the wiring diagram and on the plate applied to the unit.



The power supply cables must be protected upstream against the effects of short circuits and overload by a suitable device complying with the standards and laws in force.



The section of the cables must be commensurate with the calibration of the protection system upstream and must take into account all the factors that could influence it (temperature, type of insulation, length, etc.).



The power supply must comply with the stated limits: otherwise the warranty will be immediately voided.



The flow switch must be connected following the indications provided in the wiring diagram. Never bridge the flow switch connections in the terminal board. The warranty will no longer be considered valid if the flow switch connections have been altered or incorrectly connected.



Performed all the ground connections required by the regulations and legislation in force.



Before starting any operation make sure that the power supply is disconnected.



The electric line and the safety devices external to the unit must be sized in such a way as to guarantee the correct supply voltage at the maximum operating conditions shown in the unit's wiring diagram.



PRFROST PROTECTION:

If open, the main switch excludes the power supply to any anti-freeze device in the unit. The main switch must only be opened for cleaning, maintenance or repair of the machine or in case of stops for long periods. In these cases all necessary precautions must be taken to avoid freezing of the exchanger liquid due to temperatures below 0°C.

4.20 ELECTRICAL DATA



The following electrical data refer to the standard unit without accessories.
In all other cases, refer to the electrical data shown in the annexed wiring diagrams.



The supply voltage must not undergo variations of more than $\pm 10\%$ of the nominal value and the imbalance between the phases must be less than 1% according to the EN 60204 standard. If these tolerances are not observed, please contact our technical department.

WZA		06	08	12	16	20	24
Electrical power supply	V/~ /Hz	230/1/50 400/3+N/50	230/1/50 400/3+N/50	230/1/50 400/3+N/50	400/3+N/50	400/3+N/50	400/3+N/50
Control circuit	V	24	24	24	24	24	24
Auxiliary circuit	V	230	230	230	230	230	230
Line section (single-phase/three-phase)	mm ²	6 / 2,5	10 / 2,5	16 / 2,5	4	6	6
PE section (single-phase/three-phase)	mm ²	4 / 1,5	6 / 1,5	10 / 1,5	2,5	4	4

WZA		33	40
Electrical power supply	V/~ /Hz	400/3/50+N	400/3/50+N
Control circuit	V	24	24
Auxiliary circuit	V	230	230
Line section (single-phase/three-phase)	mm ²	10	16
PE section (single-phase/three-phase)	mm ²	6	10



The electrical data may change without notice. It is therefore necessary to always refer to the wiring diagram supplied with the unit.

4.21 ELECTRICAL CONNECTIONS

4.21.1 Power supply connection

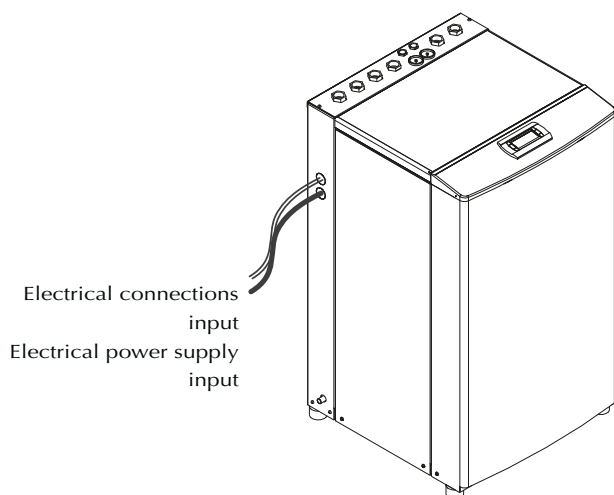

The power supply cable must be routed through one of the dedicated holes located on the left or right side of the machine, after removing the pre-cut part from the selected hole.

Connect the cable to the terminals inside the electrical panel by passing it through the appropriate cable glands in the lower part of the panel.

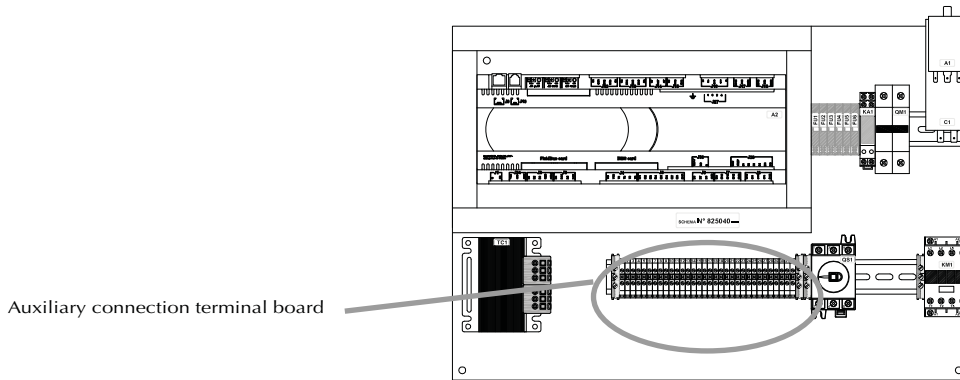

(The configuration of the electrical panel can change slightly depending on the size)



After approximately 10 minutes of operation of the heat pump, check the tightness of the screws on the power supply terminal board.



The numbering of the terminals can change without notice. For the connections it is therefore ALWAYS necessary to refer to the wiring diagram supplied with the unit.

4.21.2 Connections of the temperature probes

The unit is supplied with the following probes connected to the terminal board which must be positioned on site during installation.



Ref.	Terminals	Description	Notes
BT1		Floor probe	It is used to control the YV3 system mixer. It must be positioned on the delivery to the utility downstream of the valve. If the mixer control is not activated, the BT1 probe is used as an input probe to the geothermal heat exchanger, so it must be positioned in the well arranged on the upper connection of this component.
BT2		Domestic hot water storage probe (only in versions /R)	It is used to manage the operation in domestic hot water and heat recovery modes. It should be placed in a well installed on the domestic hot water storage. The temperature read by the probe must be close to the average temperature in the tank: the well must be placed at a height of between 1/4 and 1/2 and must have a length such as to arrive near the axis. The probe must not be struck by water flows at low or high temperature and must not be close to heat exchangers or heaters. If the unit controls an additional heat source, the probe must be positioned higher than it.
BT3		External air sensor	It is used to read the finalised external air temperature, for example to automatically correct the set points of the unit or of the mixing valves (if managed). The sensor must be positioned such that it detects the temperature of the outside air and must not be influenced by factors that could distort the reading (for example direct sunlight, other heat sources, snow/ice accumulations). As the external air sensor is supplied without protection, it is advisable to provide a protective container.
BT4		Regulation probe (utility return)	It reads the temperature of the water entering the utility exchanger that is used to manage operation of the heat pump. In the factory it is placed in a pit on the lower connection of the exchanger. This probe can be moved to a well mounted on the utility storage tank. In this way it is possible to make the utility pump not work when the compressor is in stand-by. The indications for correct positioning are the same as those given for the BT2 probe.

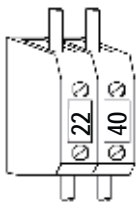
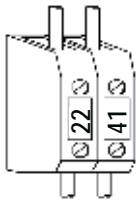
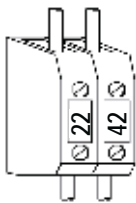
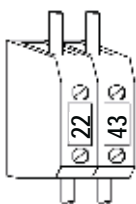
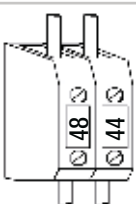
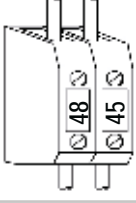
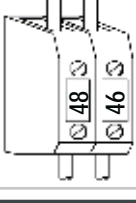

If required, it is possible to extend the connection cable by performing tin soldering suitably insulated for the junction of the wires. The length of the cable must not exceed 30 m and the section must not be less than 0.5 mm² (the use of shielded cable is recommended).

4.21.3 Auxiliary connections

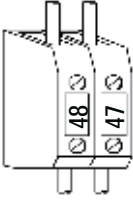
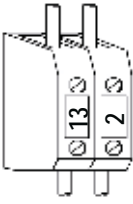
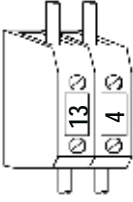
The utility terminal board inside the electrical panel contains the terminals described below. It may be necessary to change the numbering of the contacts so in order to avoid connection errors refer to the specific wiring diagram supplied with the unit.

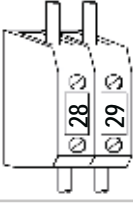
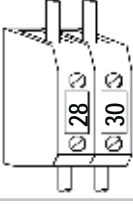
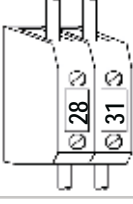
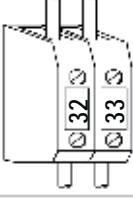
Ref.	Terminals	Description	Notes
Digital inputs			
SA1		Zone 1 room thermostat	It must be connected to the dry contact of the zone 1 room thermostat (if present). In factory it is closed with a bridge. Closed contact: user and DHW modes are active. Open contact: only DHW mode is active. When in use, remove the jumper (factory fitted) and connect the zone 1 room thermostat. If thermostat SA1 is connected, the heat pump is never enabled to heat/cool on the consumer side (regardless of the water temperature) if the thermostat is not in call.
SA2		Zone 2 room thermostat	It must be connected to the dry contact of the zone 2 room thermostat (if present).
F1		Differential pressure switch or source flow switch (version /P)	For the well /P version units, it will be necessary to connect the flow switch (supplied with the unit) to the F1 input, which must be installed on the external side (disposable water) to protect the machine in winter operation.
F3		Multifunction input	The multi-function input can be configured from the keyboard for a number of selectable functions (for example, reduced setpoint, summer/winter, on/off). Check with the company regarding the features available for the specific unit.
Analog inputs			
BT1		Floor probe	See the previous paragraph.
BT2		Domestic hot water storage probe (only in versions /R)	See the previous paragraph.
BT3		External air sensor	See the previous paragraph.

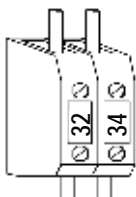
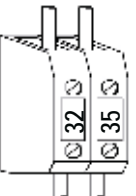
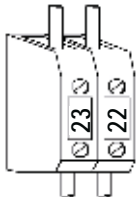
Rif.	Morsetti	Descrizione	Note
BT4		Regulation probe (utility return)	See the previous paragraph.
Digital outputs			
E1		Geothermal pump	Voltage contact for the geothermal pump control (230Vac, 1A maximum). The control is connected in the factory.
E2		System pump	Voltage contact for utility pump control (230Vac, 1A maximum). The control is connected in the factory.
E3		Domestic hot water pump	Voltage contact for domestic hot water/recovery pump control (230Vac, 1A maximum). The control is connected in the factory.
SA4		System recirculation pump or zone 1 pump	Clean contact for recirculation pump control - the function depends on the parameters set (maximum capacity 230 Vac, 1 A).
SA5		Integration of domestic hot water storage or zone 2 pump	Clean contact for control of the supplementary heat source for the domestic hot water, or of the booster pump for zone 2 - the function depends on the parameters set (maximum capacity 230 Vac, 1 A).
SA6		Integration of the system storage or domestic hot water recirculation pump	Clean contact for the control of the domestic hot water heat source for the utility, or of the booster pump on the domestic hot water - the function depends on the parameters set (maximum capacity 230 Vac, 1 A).
SA7		Heat pump diverter valve	Clean contact to control a diverter valve, whose function depends on the parameters set (maximum capacity 230 Vac, 1 A).

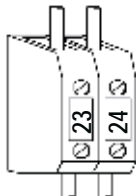
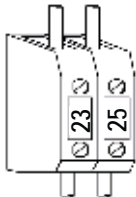
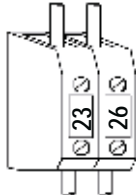
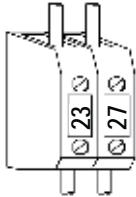
Rif.	Morsetti	Descrizione	Note
SA8		Summer/Winter mode	Clean contact to indicate the operating mode of the heat pump - Closed = Winter (maximum flow rate 230 Vac, 1 A)
SA9		General alarm	Clean contact to indicate the alarm status - Closed = Alarm (maximum flow rate 230 Vac, 1 A).
YV3		System mixing valve	24 Vac mixing valve motor power supply. Connect the neutral cable (G0) to terminal 23.
YV4		Free-cooling diverter valve	Voltage contacts for the control of the free-cooling diverter valve with 3-point motor powered at 24 Vac. Connect the neutral cable to terminal 23, the opening cable (active free-cooling) to terminal 36 and the closing cable to terminal 37.
Analogue outputs			
E1		Pompa geotermica	Segnale in tensione da 0 a 10Vdc per il controllo della velocità della pompa geotermica. Collegare il cavo di segnale al morsetto 24. Il segnale è collegato in fabbrica.
E2		Pompa Impianto	Segnale in tensione da 0 a 10Vdc per il controllo della velocità della pompa utenza. Collegare il cavo di segnale al morsetto 25. Il segnale è collegato in fabbrica.
E3		Pompa sanitario	Segnale in tensione da 0 a 10Vdc per il controllo della velocità della pompa del sanitario. Collegare il cavo di segnale al morsetto 26. Il segnale è collegato in fabbrica.
YV3		System mixing valve	Control signal of the mixing valve (in voltage from 0 to 10 Vdc). Connect the signal cable to terminal 27.

4.22 PRINCIPLE COOLING LAYOUTS

4.22.1 Single compressor unit

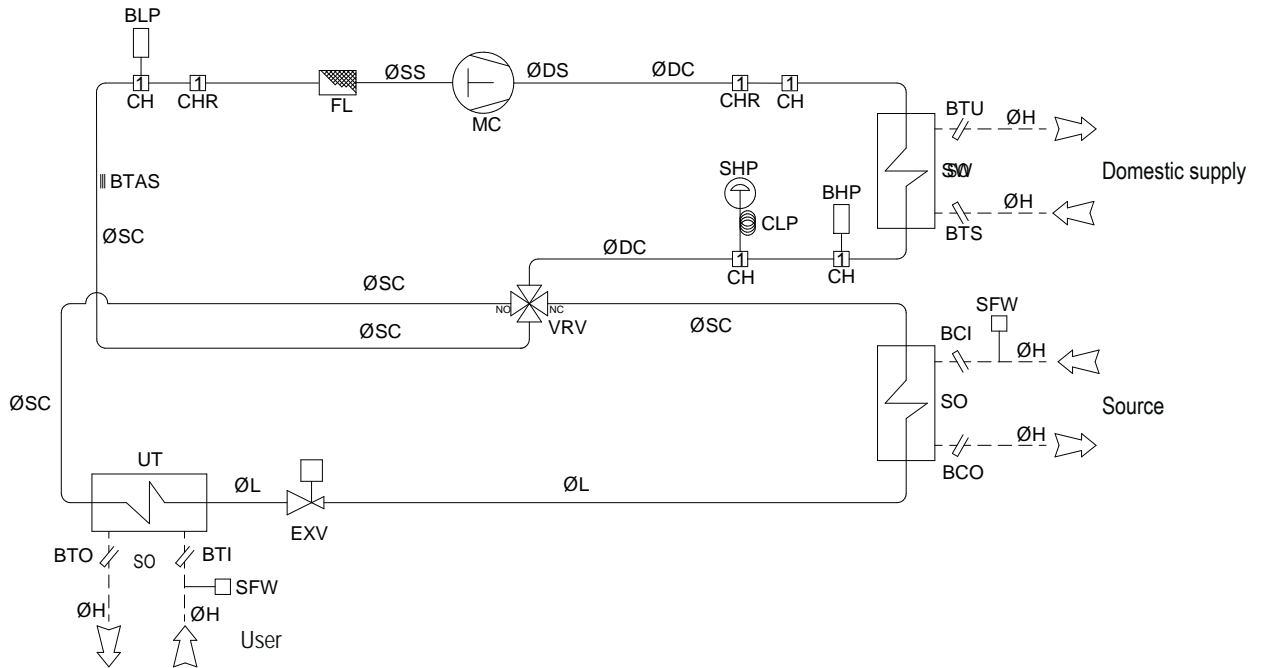

4.22.2 Double compressor unit

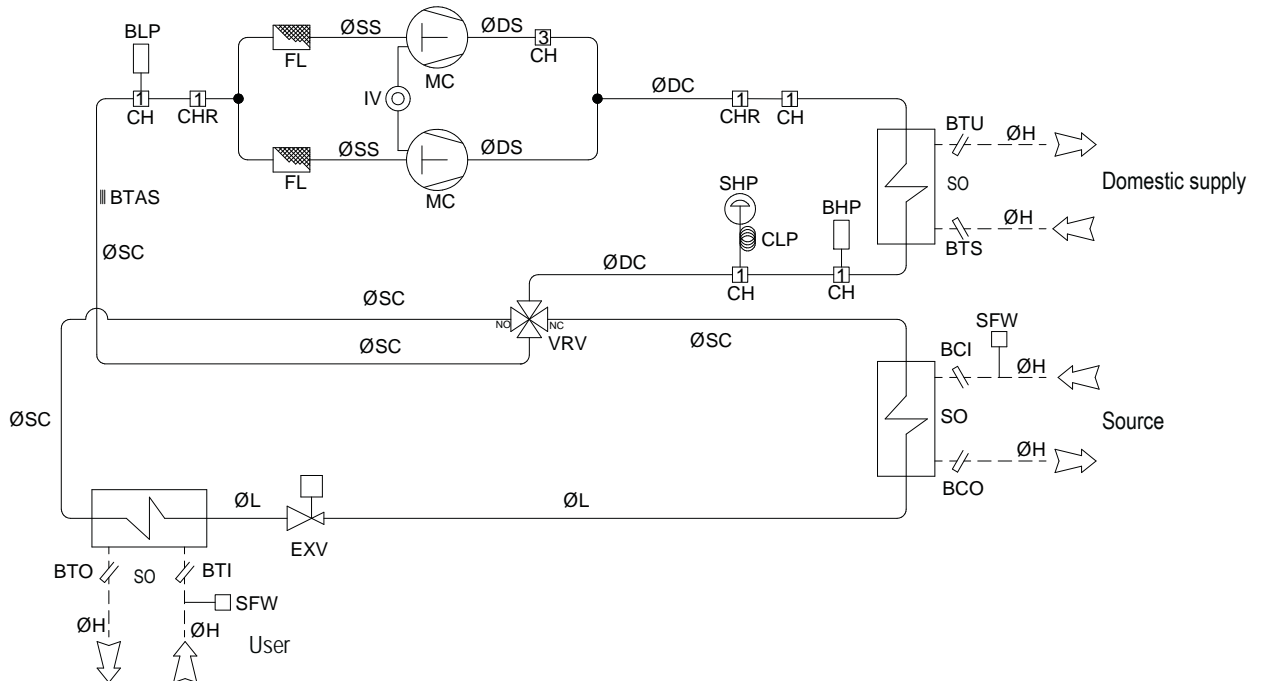

BCI	Source water inlet probe (opt.)	CHR	Load outlet
BCO	Source water outlet probe	CLP	Capillary expansion pipe
BHP	High pressure transducer	EXV	Thermostat valve
BLP	Low pressure transducer	FL	Intake line filter
BTAS	Intake temperature probe	IV	Liquid indicator
BTI	Utility water inlet probe	MC	Compressor
BTO	Utility water outlet probe	SFW	Differential pressure switch
BTS	Domestic hot water inlet probe	SHP	High pressure switch
BTU	Domestic hot water outlet probe	SO	Plate heat exchanger
CH	Load outlet	UT	Cycle reversal valve

5.1 PRELIMINARY CHECKS

Before starting the machine it is necessary to carry out preliminary checks on the electrical, hydraulic and cooling parts.



Commissioning operations must be carried out in compliance with all the provisions of the preceding paragraphs.



Never switch off the unit (for temporary shutdown) by opening the main switch: this device must only be used to disconnect the power supply unit in the absence of current flow, for example when the unit is OFF. Furthermore, as the power supply is absent, some protection devices are deactivated.

5.1.1 Before commissioning



Malfunctions or damage may also result from the lack of proper care during shipping and installation. Before installing or starting up, it is good practice to check that there are no refrigerant leaks caused by broken components or refrigeration pipes due to tampering or stresses during handling or on-site parking.

- Check that the machine is installed properly and in compliance with the instructions in this manual.
- Check the electrical connection and the correct fixing of all the terminals.
- Check that the power supply voltage is as shown on the data plate of the unit.
- Check that the machine is connected to the earthing system.
- Check that there are no gas leaks, possibly with the aid of leak detectors.
- Check that there are no oil stains that could indicate a leak.
- Check that the cooling circuit is pressurised: use the machine pressure gauges, if present, or service pressure gauges.
- Check that all the service outlets are closed with the appropriate caps.
- Check that any electrical resistors of the compressors are powered correctly.
- Check that the water connections have been carried out correctly and that circulation takes place in accordance with the indications on the plates applied to the unit.
- Check that the hydraulic systems have been properly vented and are filled to an adequate pressure.
- Check that the fluids temperatures are within the working operating limits.
- Before switching on, check that all the closing panels are in their position and secured with the appropriate screws.
- Make sure that the geothermal probes are filled with the correct anti-freeze mixture; the operation must be carried out by means of a dedicated loading pump to completely discharge the air.



Do not modify the electrical connections of the unit, otherwise the warranty will expire immediately.



If present, the electrical resistors for the compressors must be switched on at least 8 hours before start-up (pre-heating period) by closing the main switch and positioning the unit in the OFF position from the keyboard (the resistors are automatically powered when the switch is closed). The heating elements work correctly if after a few minutes the compressor casing temperature is 10÷15°C higher than the ambient temperature.



In the presence of electrical resistors for the compressors, during the 8 hours of the pre-heating period it is important to check whether the display shows the word OFF or that the unit is in stand-by. In the event of accidental start-up before the pre-heating period has elapsed, the compressors could be seriously damaged and the warranty will terminate immediately.

5.1.2 Calibration of control components

Device		Set-point	Differential	Reset type
Heating mode	°C	35	3	-----
Domestic hot water or recovery mode	°C	50	5	-----
Cooling mode	°C	23	3	-----
Frost protection thermostat	°C	4,5	4	Manual
Source pressure switch	bar	44	10	Manual
Low pressure switch	bar	3,5	10	Manual
Water safety valve	bar	3,0	-----	Automatic

5.2 OPERATING CHARACTERISTICS

5.2.1 Operating characteristics

The Set Points are defined when they are first turned on via the guided configuration procedure and subsequently modified according to requirement.

5.2.2 Set Point in cooling

Example: Set Point = 23°C, hysteresis = 3°C.

For return water temperatures above 23°C + 3°C (26°C) the compressor will start up.

For water temperatures below 23°C the compressor will be turned off.

5.2.3 Set Point in heating

Example: Set Point = 30 °C, hysteresis = 5 °C.

For return water temperatures below 25°C the compressor will start up.

For water temperatures below 30°C the compressor will be turned off.

If the power supply to the unit is restored after a momentary interruption, the set mode will be kept in memory..

5.2.4 Compressor start-up delay

To prevent start-ups of the compressor that are too close together, two functions have been set up.

Minimum time from last shutdown 180 seconds.

Minimum time from the last ignition 300 seconds.

5.2.5 Circulation pumps

The electronic board is used for management of the circulation pumps of the system, geothermal and domestic hot water hydraulic circuits that start up upon command of the heat pump regulation.

The alarm functions are activated at the time of the command.

5.2.5 Antifreeze alarm

In order to prevent breakage of the plate heat exchanger for freezing of the water contained in it, the microprocessor blocks the compressor if the temperature detected by the temperature probe at the exchanger outlet is lower than the set value.

This antifreeze set temperature can only be changed by an authorised service centre and only after verifying that a suitable antifreeze solution is present in the hydraulic circuit.

Intervention of this alarm results in blocking of the compressor and not of the pump which remains active.

To restore normal functions, the outlet water temperature must rise above the set value of a selected quantity on the heat exchanger which functions as an evaporator. Reset must be performed manually.

5.2.6 Water flow alarm

The microprocessor manages a water flow alarm controlled by a differential pressure switch/flow switch.

The intervention of this alarm results in blocking of the compressor and of the circulation pump.

To restore normal functions, the alarm must be deactivated for at least 5 seconds.

Be sure to resolve the problem before resetting the alarm.

5.2.7 Checks during operation

If the circulation pump motor is noisy, close the discharge valve slowly until normal operating conditions are reached. This problem can occur when the pressure drops are completely different from the pressure available from the pump.

5.3 CONTROL PANEL



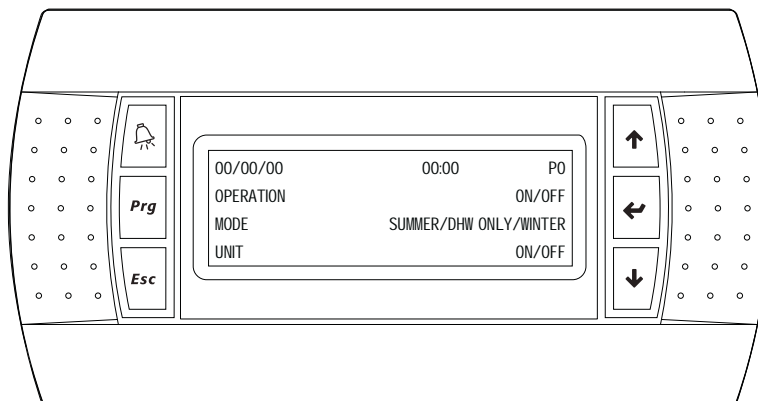

The control panel consists of a display and of programming keys



5.3.1 Display

1st line	Flashing date-time	00/00/00 - 00:00	
2nd line	Operation	ON	machine on
		OFF	machine off
3rd line	Mode	Summer	In cooling function with domestic hot water supply
		Domestic supply	Air conditioning not active. Domestic water supply
		Winter	Operating unit
4th line	Unit	On	In heating mode with domestic hot water supply
		Off	Unit in stand-by (the reason is described: switched off from the keypad, switched off by alarm, switched off by clock, etc.)

5.3.2 Functionality of the keys

	Alarms	They light up in the presence of alarm statuses. Press the button to display the type of alarm. Press again after solving the cause to reset the alarm.
Prg	Programming	Press the button to enter the set-point programming or consultation pages.
Esc	ESC	Press the key to exit the programming pages.
	Up arrow key	Move the flashing cursor to the previous page or increase the value to be modified.
	ENTER Key	To confirm and enter the parameter to be modified.
	Down arrow key	Move the flashing cursor to the next page or decrease the value to be changed.

5.3.3 Parameters

The parameters for managing the heat pump operation are grouped into three accessibility levels.

1	Without password for the User	To consult the set points and to change the date and time
2	With Maintenance Technician password	To consult and program the set points and to check the machine parameters
3	With Manufacturer password	To consult, program and change the program settings



For further information, see the control panel Manual supplied with the unit.

5.4 PROCEDURES

5.4.1 Initial configuration

On the machine:

- Set the main system switch to ON.
- Set the main door-lock switch to ON.
- The control panel display lights up.

On the Control Panel:

- Set the language of the control panel.

In case of geothermal probe:

- Perform the glycol mixing operation.
- Select pump in ON.
- Allow the geothermal circulator to run for at least 4 hours after checking that the circulator is primed and that the probes are adequately vented.

System guided configuration:

- Enter maintenance technician password
- Select system guided configuration
- Follow the step-by-step procedure, entering the required values according to the system configuration.



Make sure the geothermal circulator is primed and that the flow is guaranteed during its operation.

5.4.2 Flow switch activation (versions /P with exchange in well - disposable water)

Before starting the system:

- Lower the circuit breakers to protect the compressors
- Test the device reducing the water flow to the exchanger until it stops
- Check the alarm signal on the display and the consequent automatic release of the power contactor.



For the electrical connection of the device, follow the instructions in the wiring diagram of the unit.

5.4.3 Initial start-up

The initial start-up of the heat pump must be carried out by personnel authorised by the manufacturer.

On the machine:

- Turn OFF the general differential switch located outside the machine
- Place the remote on/off switch SA1 (see wiring diagram) in the OFF position
- First remove the front panel then the electrical panel.
- Lift the magnetothermal switch on the compressors.
- Close the cover of the electrical panel
- Place the door interlock switch in the ON position
- Put the general differential switch in the ON position.
- At this point the control panel will switch on to indicate the presence of voltage inside the machine.
- To allow the oil inside the compressor to warm up, select the OFF operation on the control panel and wait at least 8 hours before activating the unit.
- Follow the guided step-by-step configuration procedure, entering the required values according to the system configuration.



In case of operation with well water, check correct functioning of the relative flow switch.



In the case of units in the well version (/P), make sure that the water in the source is compatible with the materials of the plate heat exchanger. It is also necessary to be certain that the flow rate of the source is not lower than that indicated in the technical data of the unit. These checks must be repeated periodically to prevent dangers of serious breakages to the unit.

6.1 MAIN FUNCTIONS

6.1.1 Start-up

On the Control Panel:

- Select Mode.
- Select "Operation": On.
- The PRG button flashes for 3 min. (compressor delay) then remains on.

6.1.2 Seasonal change

On the Control Panel:

- Select "Mode".
- Choose the operating mode from: Summer, Winter, domestic hot water only.

6.1.3 Switch off

On the Control Panel:

- Select "Operation": Off.
- If on, the PRG indicator goes off.

6.1.4 Set point setting

On the Control Panel:

- Press the PRG key and then ENTER.
- Select the "Set point" menu and confirm with the Enter key.
- Choose the value to be changed using the Arrow keys.
- Change the values using the "Arrow" keys and confirm with the Enter key.



For more detailed information, refer to the Control Panel Manual supplied.

6.1.5 Current date and time setting

On the Control Panel:

- Press the PRG key.
- Select the "Clock" menu and confirm with the Enter key.
- Select "Set clock CK1" and confirm with the Enter key.
- Choose the value to be changed using the Arrow keys.
- Change the value and confirm with the Enter key.

6.1.6 Alarms

In the event of malfunctions, the Alarms symbol lights up:

- Press the Alarms button to view the alarm on the display.
- Press the Esc key to not reset.
- Press the Alarms key again to reset.



In case of operation with well water, check correct functioning of the relative flow switch.



In the case of units in the well version (/P), make sure that the water in the source is compatible with the materials of the plate heat exchanger. It is also necessary to be certain that the flow rate of the source is not lower than that indicated in the technical data of the unit. These checks must be repeated periodically to prevent dangers of serious breakages to the unit.



The '**electrical phases inverted**' alarm reset, for single-phase units, must be done in two steps:

1. reset the control,
2. switch the unit off and on again.

6.2 USER PAGES DISPLAY

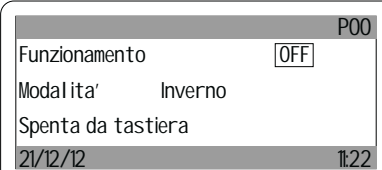
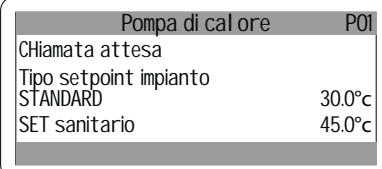
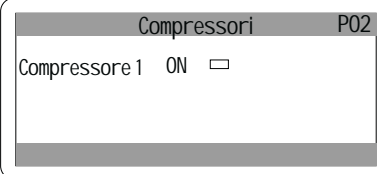
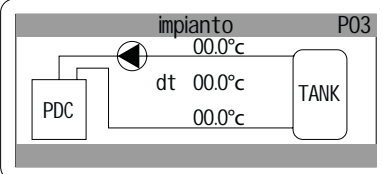
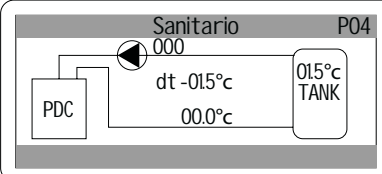
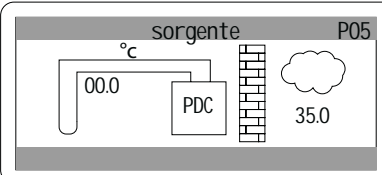
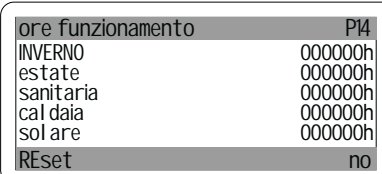
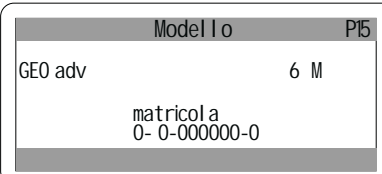
	<p>Home page where the heat pump is switched on or off and the system mode is chosen (winter, summer or domestic hot water).</p>
	<p>Display of heat pump parameters, the type of call is the type of operation that the heat pump is performing (system in winter, summer or domestic hot water). Display of heat pump current set points.</p>
	<p>Display of compressor calls.</p>
	<p>Display of system temperatures.</p>
	<p>Display of domestic hot water temperatures.</p>
	<p>Display of source and outside air temperatures.</p>
	<p>Display of operating hours in the various modes and of the various resources.</p>
	<p>Display of the heat pump model and of its serial number.</p>



If specific functions are enabled, other screens may be displayed to describe the operation of the system.

7.1 GENERAL WARNINGS



From 01 January 2016, the new European Regulation 517_2014, "*Obligations arising in relation to the containment, use, recovery and destruction of fluorinated greenhouse gases used in stationary refrigeration, air conditioning and heat pump equipment*" became enforceable. The unit in question is subject to the regulatory obligations listed below, which must be carried out by all operators:

- a) Keep the equipment register
- b) Correct installation, maintenance and repair of the equipment
- c) Loss control
- d) Refrigerant recovery and possible disposal management
- e) Presentation to the Ministry of the Environment of the annual declaration concerning atmospheric emissions of fluorinated greenhouse gases.

Maintenance allows:

- Keeping of the machine efficient.
- The prevention of any faults.
- Extending of the operating period of the unit.



It is advisable to provide a machine logbook in order to keep track of the interventions carried out on the unit, facilitating any troubleshooting.



Maintenance operations must be performed in compliance with all the provisions of the preceding paragraphs.



Use the individual protection devices required by the current regulations as the compressor heads and delivery pipes are at high temperatures and the battery fins are sharp.



If the unit is not used during the winter, the water contained in the pipes can freeze and seriously damage it. To avoid this event, carefully remove the water from the pipes, checking that all the parts of the circuit are completely emptied and that each internal or external siphon is drained.



If it is deemed necessary to replace a machine component, both for ordinary and extraordinary maintenance, this detail must have characteristics equivalent to the original part. Characteristics refer to the same or superior performances or thicknesses, which do not compromise the safety, use, handling, storage, the pressures and temperatures of use of the machine envisaged by the manufacturer.



The valves present in the machine must always be in the open position before starting. Should it be necessary to disconnect the cooling circuit by closing the valves, actions must be taken that exclude start-up of the unit even accidentally; moreover, closing of the same with appropriate signs, both on the valve and in the electrical panel, must be adequately signalled. In any case, the valves must remain closed as little as possible.

7.2 ACCESS TO THE UNIT

Access to the unit once it has been installed is only permitted to authorised operators and technicians. The owner of the machine is the legal representative of the company, body or person who owns the systems in which the machine is installed. They are responsible for complying with all the safety rules indicated in this manual and imposed by the current legislation. If, due to the nature of the place of installation, access to the machine by unauthorised persons cannot be prevented, a fenced area must be provided around the machine at least 1.5 meters away from the external surfaces, within which only authorised technicians can operate.

7.3 SCHEDULED MAINTENANCE

The user must ensure that the unit undergoes adequate maintenance based on what is indicated in the Manual and what is prescribed by the laws and local regulations in force.

The user must ensure that the unit undergoes adequate inspections, controls and periodic maintenance, based on the type, size, age and function of the system and on what is indicated in the Manual.



If leak detection tools are installed on the system, they should be inspected at least once a year to ensure they are working correctly.

During its operational life, the unit must undergo inspections and checks based on the local laws and regulations in force. In particular, when there are no more stringent specifications, the indications provided in the following table must be followed (see EN 378-4, ann. D), with reference to the situations described.

SITUATION	Visual inspection	Pressure test	Search for leaks
A	X	X	X
B	X	X	X
C	X		X
D	X		X

A	Inspection, after an intervention, with possible effects on mechanical strength, or after a change of use, or after inactivity of over two years; any unsuitable components must be replaced. Checks must not be carried out at pressures higher than the design.
B	Inspection following a repair, or a significant change to the system, or to its components. Verification may be limited to the parts involved in the intervention, but if a refrigerant leak is detected, it will be necessary to perform a leak search on the entire system.
C	Inspection following installation of the machine in a position other than the original one. If it is possible to have effects on the mechanical resistance, refer to point A.
D	Leak detection, due to a well-founded suspicion of refrigerant leakage. The system must be examined to identify leaks, through direct measures (use of systems able to highlight the leak) or indirect measures (deduction of the presence of the leak based on the analysis of the operating parameters), focusing on the parts most subject to releases (for example, joints).



If a defect is detected that compromises reliable operation, the unit cannot be put back into operation before that same defect has been eliminated.

7.4 PERIODIC AND INITIAL START-UP CHECKS



Commissioning operations must be carried out in compliance with all the provisions of the preceding paragraphs.



- All the operations described in this chapter **MUST ALWAYS BE PERFORMED BY QUALIFIED PERSONAL**.
- Before carrying out any work on the unit or accessing internal parts, make sure that the power supply has been disconnected.
- The compressor heads and delivery piping are usually found at high temperatures.
- After maintenance operations, close the panels and secure them with the fixing screws.

7.4.1 Electrical system and control devices

Operations to be performed	Frequency			
	Every month	Every 6 months	Every year	When required
Check that the unit is working properly and that there are no alarms	X			
Inspect the unit visually	X			
Check the noise and vibration of the unit		X		
Check the functionality of the safety devices and interlocks			X	
Check the performance of the unit			X	
Check the electrical consumption of the various utilities (compressors, fans, etc.)			X	
Check the supply voltage of the unit		X		
Check the fixing of the cables in the relative terminals		X		
Check the integrity of the insulating coating of the electric cables			X	
Check the status and operation of the contactors			X	
Check the functioning of the microprocessor and of the display		X		
Clean the electrical and electronic components from any dust present			X	
Check the operation and calibration of the probes and transducers			X	

7.4.2 Refrigerant and hydraulic circuits

Operations to be performed	Frequency			
	Every month	Every 6 months	Every year	When required
Check the pressure of the hydraulic circuits and any leaks	X			
Check that the flow switch is working properly		X		
Clean the metal filter placed on the water pipe (1)		X		
Check the 4-way valve operation (if present)			X	
Check for the presence of air in the hydraulic circuit	X			
Check the colour of the humidity indicator			X	
Check for freon leaks (2)				X



⁽¹⁾ It can be performed more frequently (even weekly) depending on the temperature difference.



⁽²⁾ To perform operations on the refrigerant it is necessary to comply with the European regulation 517_2014, "Obligations arising in relation to the containment, use, recovery and destruction of fluorinated greenhouse gases used in fixed refrigeration, air conditioning and heat pump equipment".

7.4.3 Compressors

Operations to be performed	Frequency			
	Every month	Every 6 months	Every year	When required
Inspect the compressors visually		X		
Check the noise and vibrations of the compressors		X		
Check the supply voltage of the compressors		X		
Check the electrical connections of the compressors			X	
Check the oil level in the compressors by means of the dedicated light (if present)		X		
Check that the casing heaters are powered and working properly (if present)			X	
Check the condition of the electrical cables of the compressors and their fixing in the terminals		X		



Monthly operations can be performed directly by the system owner. The other interventions must be carried out by qualified and adequately trained personnel.



Any cleaning operation is prohibited, before the appliance has been disconnected from the power supply, by turning the main switch to the OFF position. It is forbidden to touch the appliance barefoot or with wet or damp parts of the body.



Work on the cooling circuit must be carried out by suitably qualified and trained technicians, enabling in compliance with the current local laws and regulations.



Before the first start-up it is necessary to perform all the operations described in the previous tables and to make the necessary checks required by the pre-start control form (valid for Italy) to be requested from the service.

7.5 Cooling circuit repair



If leak detection tools are installed on the system, they should be inspected at least once a year to ensure they are working correctly.

The system must be filled with nitrogen using a cylinder fitted with a reduction valve up to a pressure of approximately 15 bar. Any leaks must be identified by a leak detector device. The appearance of bubbles or foam indicates the presence of localised leaks. In this case, discharge the circuit before carrying out repairs with appropriate alloys..



Never use oxygen instead of nitrogen: high risk of explosion.

Cooling circuits operating with refrigerant gas require special care in assembly and maintenance, in order to protect them from malfunctions. The following are therefore necessary:

- Avoid refilling using oil different from that specified already pre-loaded in the compressor.
- For machines that use refrigerant, if there are gas leaks that result in the circuit being even partially discharged, avoid topping up the refrigerant, but instead completely discharge the machine, recovering the refrigerant for subsequent disposal and after emptying, refill them with the specified quantity.
- When replacing any part of the refrigeration circuit, do not leave the circuit open for more than 15 minutes.
- In particular, if the compressor is replaced, complete the installation within the time indicated above, after removing the rubber caps.
- If the compressor is replaced, it is advisable to wash the cooling circuit with suitable products and to insert an antacid filter for a certain period.
- In empty conditions do not supply voltage to the compressor; do not compress air inside the compressor.

8.1 Disconnecting the unit



All the decommissioning operations must be performed by qualified personnel in compliance with the national legislation in force in the destination country.

- Avoid spills or leaks of any fluid into the environment.
- Before disconnecting the machine recover if present:
 - the refrigerant gas;
 - the non-freezing solutions of the hydraulic circuit;
 - the lubricating oil of the compressors.

While awaiting decommissioning and disposal, the machine can also be stored outdoors, provided the unit has undamaged and closed electrical, refrigeration and hydraulic circuits.

8.2 Decommissioning, disposal and recycling

The structure and the various components, if unusable, must be demolished and divided according to their nature; with particular regard to the copper and aluminium present in small quantities in the machine.

All the materials must be recovered or disposed of in compliance with the relevant national regulations.



The cooling circuit contains oil which constrains the methods of disposal of the components.

8.3 WEEE Directive (EU only)

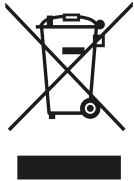

The symbol of the crossed-out bin, present on the label placed on the appliance, indicates compliance of this product with the legislation on waste electrical and electronic equipment. Discarding into the environment of the equipment or abusive disposal of the same are punishable by law.

This product falls within the scope of application of Directive 2012/19/EU concerning the management of waste electrical and electronic equipment (WEEE).

The appliance must not be eliminated with domestic waste as it is composed of different materials that can be recycled at suitable facilities. Obtain information, through the municipal authority, on the location of the ecological platforms suitable for receiving the product for disposal and its subsequent correct recycling.

The product is not potentially dangerous for human health and the environment, as it does not contain harmful substances according to Directive 2011/65/U (RoHS), but if left in the environment it can negatively impact on the ecosystem.

Read the instructions carefully before using the appliance for the first time. It is highly recommended not to use the product for any purpose other than that for which it was intended, as there is a danger of electric shock if used improperly.

9.1 Troubleshooting

All the units are controlled and tested at the factory before shipment, however it is possible that some anomaly or failure may occur during operation. The following are the indications necessary to identify the causes of the most common cases.



IT IS ADVISABLE TO RESET AN ALARM ONLY AFTER REMOVING THE CAUSE THAT HAS GENERATED IT; REPEATED RESETS CAN RESULT IN IRREVERSIBLE DAMAGE TO THE UNIT. IN CASE OF ALARM, READ THE MESSAGE THAT APPEARS ON THE DISPLAY BEFORE PROCEEDING TO RESET.

Problem	Description	Cause
High pressure circuit 1	First high pressure safety intervention level of cooling circuit 1 from high transducer (electronic interruption)	No water circulation on the system side hydraulic circuit in winter mode.
		No water circulation on the hydraulic circuit on the source side (geothermal probe or well) in summer mode.
		No domestic hot water side hydraulic circuit circulation in domestic hot water mode.
High pressure from circuit pressure switch 1	Second level of high pressure safety intervention of cooling circuit 1 from pressure switch (mechanical interruption with manual reset of the pressure switch)	No operation of the high pressure transducer.
		No water circulation on the system side hydraulic circuit in winter mode.
		No water circulation on the hydraulic circuit on the source side (geothermal probe or well) in summer mode.
Gas antifreeze circuit 1	Compressor intake probe safety intervention of the cooling circuit 1	No domestic hot water side hydraulic circuit circulation in domestic hot water mode.
		Insufficient water circulation on the source side circuit (geothermal probe or well) in winter mode or in domestic hot water mode.
Low pressure circuit 1	Low pressure safety intervention of cooling circuit 1 from low transducer (electronic interruption)	Insufficient water circulation on the system hydraulic circuit in summer mode.
		Refrigerant gas discharge machine.
		Incorrect setting of the domestic hot water side hydraulic circuit parameters.
System water antifreeze	System-side hydraulic circuit delivery probe safety intervention	Plant water temperature close to freezing.
Domestic hot water antifreeze	Domestic hot water side hydraulic circuit delivery probe safety intervention	Domestic hot water temperature close to freezing.
Source water antifreeze	Source side hydraulic circuit delivery probe safety intervention (geothermal probe or well)	Source water side temperature (geothermal probe or well) close to freezing.
High pressure transducer error	High pressure transducer with incorrect reading	Incorrect full scale reading of the high pressure transducer, viewable on the keyboard on the machine (M9 window).
Low pressure transducer error	Low pressure transducer with incorrect reading	Incorrect full scale reading of the low pressure transducer, viewable on the keyboard on the machine (M9 window).
System water inlet probe error	System water return temperature probe with incorrect reading	Temperature probe cable interrupted or disconnected.
System water outlet probe error	System water delivery temperature probe with incorrect reading	Temperature probe cable interrupted or disconnected.
Boiler water probe error	Domestic hot water storage tank temperature probe with incorrect reading	Temperature probe cable interrupted or disconnected.
Domestic hot water outlet probe error	Domestic hot water delivery temperature probe with incorrect reading	Temperature probe cable interrupted or disconnected.
Electrical phases inverted	The discharge pressure does not increase with respect to the intake pressure with the compressor active	The power supply phases are reversed.
		The control requires the compressor to start, but this does not start.
		The compressor works but does not generate pressure differences.
Geothermal water outlet probe error	Geothermal flow temperature probe with incorrect reading	Temperature probe cable interrupted or disconnected.
Geothermal water inlet probe error	Geothermal return temperature probe with incorrect reading	Temperature probe cable interrupted or disconnected.
Floor probe error	Radiant system delivery temperature probe with incorrect reading	Temperature probe cable interrupted or disconnected.

Problem	Description	Cause
Outdoor air probe error	Outdoor air temperature probe with incorrect reading	Temperature probe cable interrupted or disconnected.
Compressor intake probe error	Compressor intake temperature probe with incorrect reading	Temperature probe cable interrupted or disconnected.

9.2 Possible anomalies and possible remedies

Problem	Description	Cause
The heat pump does not start	<ul style="list-style-type: none"> - No voltage - Main switch in pos. OFF - Remote switch in OFF - Control panel in OFF - Main switch in OFF - Compressor magnetothermal switch in OFF - Low supply voltage - Faulty remote control coil - Compressor capacitor defective (single-phase unit) - Compressor defective 	<ul style="list-style-type: none"> - Check for voltage - Check upstream safety systems - Set to ON - Set to ON - Set to ON - Set to ON - Set to ON - Check the power supply line - Replace the component - Replace the component - Replace the component
Insufficient performance	<ul style="list-style-type: none"> - No refrigerant - Incorrect sizing of the equipment - Operation outside the operating conditions recommended by the manufacturer 	<ul style="list-style-type: none"> - Check filling level - Check - Check parameters
Noisy compressor	<ul style="list-style-type: none"> - Part of the refrigeration circuit in contact with the carpentry - Liquid return to the compressor - Inadequate fixing of the unit - Power cable with inverted phase 	<ul style="list-style-type: none"> - Check - Check - Check - Reverse a phase
Noises and vibrations	<ul style="list-style-type: none"> - Contacts on metal parts - Loose or missing screws 	<ul style="list-style-type: none"> - Check - Tighten the screws
Raised pressure	<ul style="list-style-type: none"> - High geothermal circuit water temperature in summer mode - High water temperature in winter mode - High sanitary circuit water temperature - Abnormal operation of the 2-way valve on the well side in Summer operation - Air in the hydraulic system in winter/domestic hot water mode - Thermostatic expansion valve faulty - In summer operation, insufficient flow to the geothermal exchanger - In domestic hot water function, insufficient flow to the domestic hot water exchanger - In winter function, insufficient flow to the system exchanger - Plate heat exchanger in operation, condenser blocked 	<ul style="list-style-type: none"> - Check - Check - Check - Check and replace the component if necessary - Vent the air from the circuit - Check and replace the component if necessary - Check the pump - Check the pump - Check the pump - Check and replace the component if necessary
Low suction pressure	<ul style="list-style-type: none"> - Well water low temperature or geothermal ring in winter or domestic hot water mode - Low water inlet temperature of the system in summer mode - Abnormal operation of the 2-way valve on the well side in heating or domestic hot water mode - Exhaust cooling circuit - Plate heat exchanger when the evaporator is blocked 	<ul style="list-style-type: none"> - Check - Check - Check and replace the component if necessary - Check for leaks and refill - Check and replace the component if necessary

Problem	Description	Cause
High intake pressure	<ul style="list-style-type: none"> - Well water high temperature or geothermal ring in winter or domestic hot water mode - High water inlet temperature of the system in summer mode - Thermostatic expansion valve faulty 	<ul style="list-style-type: none"> - Check - Check - Check and replace the component if necessary
The compressor stops due to the intervention of the protections	<ul style="list-style-type: none"> - Excessive delivery pressure - Low intake pressure - Low supply voltage - Electrical connections poorly tightened - Operation outside the permitted limits - Poor functioning of the probes and pressure switches - Thermal protection intervention 	<ul style="list-style-type: none"> - Check - Check - Check - Check - Check - Replace the component - Check power supply voltage - Check the electrical insulation of the windings
High electrical consumption	<ul style="list-style-type: none"> - Cooling circuit pressure too high with respect to that recommended by the manufacturer - Non-compliant voltage - Operation outside the permitted limits 	<ul style="list-style-type: none"> - Check the maximum consumption foreseen by the data plate and characteristics - Check the power supply voltage - Check
Reverse phase alarm	<ul style="list-style-type: none"> - Three-phase unit with wrongly cabled phases - Single-phase unit with alarming softstarter 	<p>Operate as follows:</p> <ul style="list-style-type: none"> - Switch the power off - Check if the sequence of wiring is correct - Turn the power on - Reset the alarm



ESEX TECHNOLOGIES

VIA DELLE INDUSTRIE, 7 • CAP 31030 • VACIL DI BREDA DI PIAVE (TV)
TEL. +39 0422 605 311

Info@enextechnologies.com • www.enextechnologies.com

Technical data shown in this booklet are not binding.

The Company shall have the right to introduce at any time whatever modifications necessary to the improvement of the product.
The reference languages for the whole documentation are Italian and English. The other languages are to be considered only as guidelines.